



# UniTower

## GHRFG SERIES

Available in 42 Standard Sizes 24 to 840 Tons



*Single Fan Unit up to 313 Tons*

# *The All-Fiberglass Cooling Tower*



*Quadruple Fan Unit up to 840 Tons*

*Thermal  
Performance  
Certified by the  
Cooling Tower  
Institute #00-22-02*

# **REYMSA COOLING TOWERS, INC.**

# GHRFG SERIES

The UniTower Series GHRFG by REYMSA, is the result of more than 30 years of experience in the Cooling Tower engineering applications.

The UniTower is an All-Fiberglass Unitized Tower, Completely factory assembled with basin and body in one molded fiberglass piece, and in smaller models even the fan cylinder is unitized to the basin-body casing.

The UniTower is available in 17 basic cells sizes with 42 standard models to provide a more accurate

The Thermal Performance of the UniTower Series GHRFG, product line GHR, has been certified by the Cooling Tower Institute, under Certification Number 00-22-02, according to its standard STD-201-96.

The REYMSA Cooling Towers advanced technology has been improving continuously at our Research and Development Center.

## FEATURES

- All Fiberglass Unitized Casing
- UV Protection for Extended Life & Strength
- All Fiberglass Reinforced Structure
- Fiberglass-Reinforced-Polyamide Adjustable Pitch Fans
- PVC Fill & PVC Drift Eliminator
- Direct Drive, Low Speed, TEFC, NEMA Fan Motors
- Low Noise Operation
- No moving Internal Parts
- Fixed Distribution Nozzles with Variable Flow Rates
- Optional Air Inlet Fiberglass Louvers or PVC Panels
- Optional FRP or HDGS motors support
- Large, Easy Removable Access Doors
- Bottom Drain Sump Available at No Charge
- Single or Multiple Fan Configurations with Common Sump

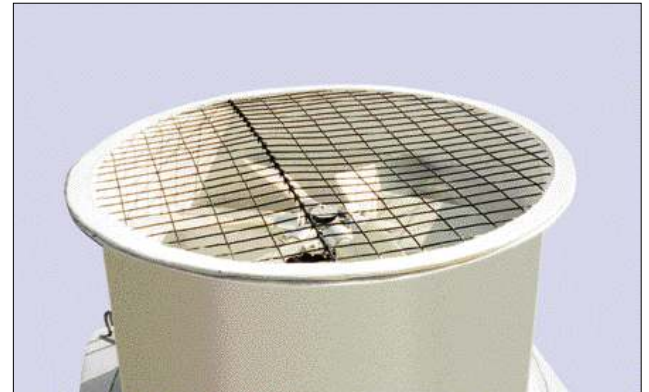

Directly Drive Axial Fan with Galvanized Steel PVC Coated Screen Guard

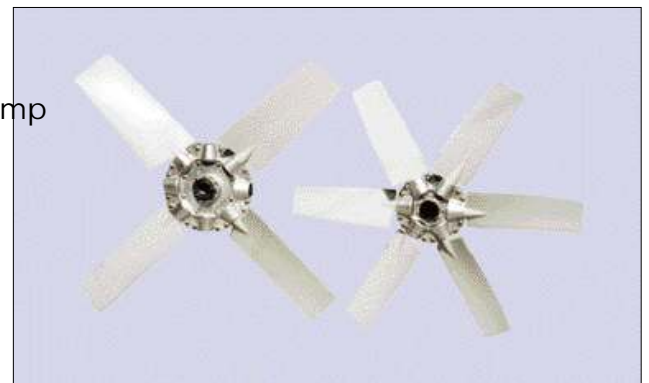

Fiberglass-reinforced-polyamide adjustable pitch blades with Pressure Die Cast Aluminium Hub



2 1/2" N.P.T. ABS-Spray nozzles with interchangeable internal devices



PVC Fill and Drift Eliminator



Cooling Tower without access door

## COMPONENTS

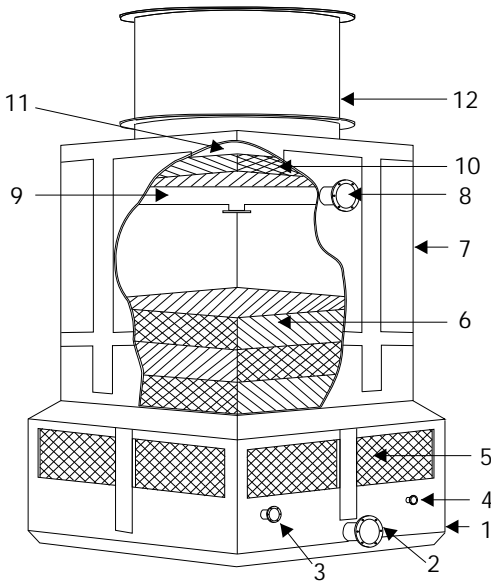

- |                      |                          |
|----------------------|--------------------------|
| 1. Basin Section     | 8. Hot Water Inlet       |
| 2. Cool Water Outlet | 9. Spray Nozzle Manifold |
| 3. Overflow          | 10. Drift Eliminator     |
| 4. Water Make-up     | 11. Plenum               |
| 5. Air Inlet Louvers | 12. Fan Section          |
| 6. Cellular Fill     | 13. Drain (back side)    |
| 7. Body Section      | 14. Purge (back side)    |

Component numbers directly correspond to the numbered columns on the Chart below.

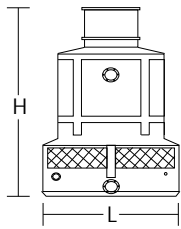
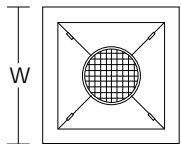

Single Fan GHRFG

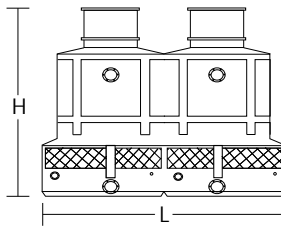
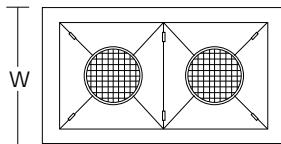

Double Fan GHRFG

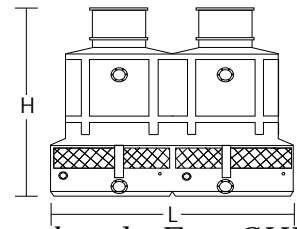
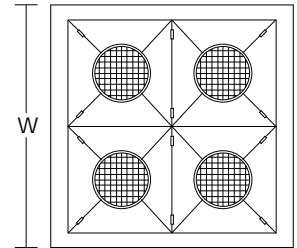

Quadruple Fan GHRFG

MODEL GHRFG	DIMENSIONS			CONNECTION DIAMETER						BASIN CAP.	WEIGHT	
	L	W	H	2	3	4	8	13	14		SHIPPING	OPERATING
3031	47.24	47.24	113.70	2½	2	½	2½	2	½	97	766	1503
4041	58.66	58.66	117.70	2½	2	½	2½	2	½	151	1076	2352
5051	70.47	70.47	128.06	4	2	½	4	2	¾	217	1438	3357
6061	83.07	83.07	136.69	4	2	½	4	2	¾	296	1990	4648
7071	90.94	90.94	147.11	6	2	1	6	2	¾	355	2688	5921
7081	90.94	103.15	147.11	6	2	1	6	2	¾	401	2861	6558
7091	94.94	114.96	147.11	6	2	1	6	2	¾	448	3066	7225
8081	103.15	103.15	148.17	6	2	1	6	2	¾	454	3144	7361
8091	103.15	114.96	148.17	6	2	1	6	2	¾	506	3350	8086
8101	103.15	126.77	148.17	6	2	1	6	2	¾	558	3735	8971
8111	103.15	138.58	151.99	8	2	1½	8	2	¾	611	4002	9744
8121	103.15	150.39	151.99	8	2	1½	8	2	¾	663	4240	10490
7142	174.02	90.94	154.61	2-6	2-2	2-1	2-6	2-2	2-¾	710	4921	11388
8162	198.43	103.15	155.67	2-6	2-2	2-1	2-6	2-2	2-¾	872	5765	13909
14144	168.20	168.20	206.63	2-8	2-2	2-1½	2-8	4-2	2-¾	2097	9842	22776
16164	192.9	194.88	207.71	2-10	2-2	2-1½	2-8	4-2	2-¾	2739	11530	27818

- All dimensions, weights and capacities are expressed in inches, pounds and gallons. Physical dimensions of each tower are approximate and are subject to change.
- All double and quadruple models have double fittings and connections.

# GHRFG SERIES

## OPTIONAL ACCESSORIES

- Bottom Outlet (Dry Sump)
- Ladders
- Service Platform
- Electrical Junction Box
- Basin Heaters
- Vibration Isolators
- Control Panels
- Flumes
- Step Controllers
- Vibration Cut-off Switch
- Electrical Float Controls



GHRFG1616410 Model



GHRFG5555175 Model

## GHRFG SERIES TOWER SELECTION

### EXAMPLE:

Select the GHRFG Model REYMSA Cooling Tower to cool 1200 GPM of clear water from 95°F to 85°F at entering air wet bulb of 78°F.

**Step 1 RANGE** is equal to the temperature differential between the entering water temperature (T1) and the leaving water temperature (T2).  $(95^{\circ}\text{f} - 85^{\circ}\text{f}) = 10$

**Step 2 APPROACH** is equal to the temperature differential between the leaving cool water temperature (T2) and wet bulb temperature (TWB),  $(85^{\circ}\text{F} - 78^{\circ}\text{F}) = 7$

**Step 3 From Selection A: TOWER SELECTION FACTORS**; Select the appropriate wet bulb temperature table (78°F). Select the Range column (10) and in Approach row (7), the Tower Selection Factor = 4.8

**Step 4 Next, go to Section B: CAPACITY TABLES**; Enter the column headed by the "Tower Selection Factor" determined from Section A (4.8) and read down that column to the desired cooling water flow rate equal to or greater than that specified (1200 gpm). Look to the left on the row with the desired cooling water flow and read the corresponding GHRFG816215 REYMSA Cooling Tower model to satisfy your requirements.

## Section A: TOWER SELECTION FACTORS

### 60 Deg. Wet Bulb

APPROACH	R A N G E								
	6	8	10	12	15	20	26	30	35
5	3.15	2.70	2.43						
6	3.60	3.03	2.73	2.49					
7	4.05	3.42	3.00	2.73	2.49				
8	4.50	3.75	3.36	3.00	2.70	2.40			
10	5.49	4.50	3.96	3.60	3.21	2.79	2.55	2.40	
12	6.36	5.31	4.59	4.14	3.66	3.18	2.88	2.76	2.61
14		6.00	5.25	4.65	4.14	3.60	3.21	3.09	2.88
16			5.91	5.25	4.62	4.05	3.60	3.45	3.21

### 62 Deg. Wet Bulb

APPROACH	R A N G E								
	6	8	10	12	15	20	26	30	35
5	3.33	2.85	2.55	2.34					
6	3.78	3.21	2.88	2.61	2.37				
7	4.26	3.75	3.18	2.91	2.61	2.34			
8	4.65	3.96	3.51	3.18	2.85	2.55	2.31		
10	5.70	4.71	4.14	3.78	3.33	2.88	2.67	2.55	2.40
12	6.75	5.55	4.80	4.32	3.84	3.36	3.00	2.91	2.73
14		6.45	5.55	4.95	4.35	3.81	3.39	3.24	3.06
16			6.21	5.55	4.85	4.23	3.78	3.63	3.45

# COOLING TOWERS

## 63 Deg. Wet Bulb

APPROACH	R A N G O								
	6	8	10	12	15	20	26	30	35
5	3.42	2.88	2.58	2.40					
6	3.90	3.30	2.91	2.67	2.43				
7	4.35	3.66	3.21	2.94	2.67	2.40			
8	4.80	4.05	3.54	3.24	2.91	2.61	2.37		
10	5.85	4.80	4.23	3.81	3.42	3.00	2.73	2.64	2.49
12		5.61	4.89	4.41	3.96	3.48	3.12	2.97	2.79
14		6.54	5.61	5.04	4.44	3.90	3.54	3.36	3.15
16			6.36	5.64	5.04	4.35	3.90	3.75	3.54

## 64 Deg. Wet Bulb

APPROACH	R A N G O								
	6	8	10	12	15	20	26	30	35
5	3.54	2.97	2.64	2.43					
6	4.02	3.39	2.91	2.73	2.49				
7	4.47	3.75	3.30	3.00	2.76	2.46			
8	5.01	4.14	3.63	3.30	2.97	2.70	2.43	2.31	
10	6.00	4.95	4.29	3.90	3.54	3.09	2.82	2.67	2.55
12		5.79	5.01	4.50	4.02	3.60	3.21	3.00	2.91
14		6.60	5.70	5.16	4.56	3.99	3.63	3.39	3.24
16			6.36	5.85	5.16	4.50	4.02	3.78	3.63

## 66 Deg. Wet Bulb

APPROACH	R A N G O								
	6	8	10	12	15	20	26	30	35
5	3.72	3.21	2.82	2.61	2.37				
6	4.26	3.63	3.15	2.91	2.61	2.37			
7	4.74	3.99	3.54	3.21	2.88	2.61	2.37		
8	5.31	4.41	3.84	3.54	3.12	2.82	2.55	2.43	2.34
10	6.36	5.19	4.59	4.17	3.72	3.27	2.91	2.82	2.70
12		6.09	5.31	4.80	4.26	3.75	3.36	3.21	3.03
14			6.06	5.52	4.80	4.26	3.78	3.60	3.42
16				6.15	5.46	4.71	4.23	3.99	3.81

## 68 Deg. Wet Bulb

APPROACH	R A N G O								
	6	8	10	12	15	20	26	30	35
5	3.93	3.33	2.94	2.73	2.49	2.25			
6	4.41	3.75	3.30	3.03	2.91	2.49	2.28		
7	4.95	4.17	3.69	3.39	3.00	2.70	2.49	2.40	2.31
8	5.55	4.59	4.05	3.72	3.30	2.94	2.70	2.61	2.49
10	6.75	5.52	4.74	4.35	3.90	3.42	3.09	2.97	2.85
12		6.45	5.58	5.04	4.44	3.93	3.57	3.39	3.21
14			6.36	5.76	5.04	4.41	3.99	3.81	3.60
16				6.51	5.70	4.95	4.41	4.26	4.02

## 70 Deg. Wet Bulb

APPROACH	R A N G O								
	6	8	10	12	15	20	26	30	35
5	4.05	3.54	3.12	2.88	2.61	2.37			
6	4.56	3.96	3.51	3.21	2.91	2.61	2.40	2.31	
7	5.16	4.41	3.90	3.54	3.21	2.85	2.64	2.52	2.43
8	5.46	4.89	4.26	3.90	3.51	3.06	2.85	2.73	2.67
10		5.82	5.04	4.56	4.11	3.60	3.30	3.15	3.00
12		6.90	5.91	5.34	4.65	4.14	3.78	3.60	3.48
14			6.75	6.00	5.34	4.65	4.23	4.02	3.87
16				5.94	5.28	4.74	4.47	4.32	

## 72 Deg. Wet Bulb

APPROACH	R A N G O								
	6	8	10	12	15	20	26	30	35
5	4.35	3.69	3.27	3.00	2.73	2.52	2.31		
6	4.95	4.14	3.72	3.42	3.03	2.79	2.55	2.43	2.34
7	5.55	4.59	4.11	3.75	3.36	3.03	2.79	2.67	2.55
8	6.09	5.04	4.47	4.11	3.69	3.30	3.00	2.85	2.79
10		6.00	5.34	4.80	4.32	3.84	3.51	3.30	3.18
12			6.15	5.55	5.01	4.38	3.93	3.78	3.60
14				6.36	5.64	5.04	4.44	4.26	4.05
16					6.36	5.61	5.04	4.71	4.50

## 73 Deg. Wet Bulb

APPROACH	R A N G O								
	6	8	10	12	15	20	26	30	35
5	4.38	3.78	3.39	3.12	2.82	2.55	2.40	2.28	
6	4.98	4.29	3.81	3.54	3.18	2.85	2.64	2.52	2.40
7	5.58	4.71	4.23	3.93	3.51	3.09	2.91	2.73	2.64
8	6.15	5.25	4.62	4.26	3.78	3.42	3.09	2.94	2.85
10		6.21	5.55	4.89	4.44	3.96	3.60	3.42	3.27
12			6.36	5.79	5.10	4.50	4.11	3.90	3.72
14				6.60	5.79	5.10	4.65	4.35	4.17
16					6.45	5.70	5.16	4.86	4.59

## 74 Deg. Wet Bulb

APPROACH	R A N G O								
	6	8	10	12	15	20	26	30	35
5	4.47	3.84	3.48	3.18	2.91	2.67	2.43	2.37	2.28
6	5.19	4.35	3.90	3.60	3.24	2.91	2.67	2.58	2.49
7	5.76	4.86	4.32	3.96	3.60	3.21	2.91	2.82	2.70
8	6.90	5.34	4.74	4.32	3.90	3.48	3.18	3.00	2.91
10		6.36	5.61	5.13	4.56	4.05	3.66	3.54	3.39
12			6.60	5.88	5.31	4.59	4.14	3.99	3.84
14				6.75	6.00	5.22	4.68	4.47	4.29
16					5.85	5.25	5.04	4.77	

# GHRFG SERIES

## 75 Deg. Wet Bulb

APPROACH	R A N G O								
	6	8	10	12	15	20	26	30	35
5	4.62	3.96	3.54	3.27	3.00	2.70	2.52	2.40	2.34
6	5.31	4.44	3.99	3.66	3.36	2.97	2.79	2.67	2.55
7	5.91	5.01	4.41	4.05	3.69	3.30	3.00	2.88	2.79
8	6.45	5.52	4.89	4.41	4.02	3.60	3.30	3.09	2.97
10		6.06	5.76	5.16	4.71	4.17	3.81	3.60	3.36
12			6.66	6.00	5.46	4.71	4.32	4.05	3.90
14					6.15	5.40	4.86	4.56	4.38
16						6.00	5.40	5.16	4.89

## 76 Deg. Wet Bulb

APPROACH	R A N G O								
	6	8	10	12	15	20	26	30	35
5	4.71	4.05	3.69	3.42	3.06	2.79	2.61	2.49	2.40
6	5.40	4.56	4.14	3.78	3.45	3.09	2.85	2.73	2.64
7	6.00	5.10	4.53	4.17	3.78	3.42	3.12	2.97	2.85
8	6.75	5.61	5.04	4.56	4.14	3.72	3.42	3.24	3.06
10		6.75	5.91	5.40	4.80	4.29	3.90	3.72	3.60
12				6.15	5.55	4.89	4.44	4.26	4.05
14					6.24	5.55	5.04	4.74	4.50
16						6.15	5.58	5.28	5.10

## 77 Deg. Wet Bulb

APPROACH	R A N G O								
	6	8	10	12	15	20	26	30	35
5	4.86	4.20	3.75	3.48	3.18	2.91	2.67	2.55	2.49
6	5.55	4.71	4.23	3.87	3.54	3.21	2.91	2.79	2.70
7	6.15	5.28	4.59	4.29	3.87	3.51	3.18	3.06	2.94
8		5.79	5.10	4.65	4.26	3.84	3.45	3.30	3.21
10			6.00	5.52	4.95	4.41	3.99	3.81	3.69
12				6.36	5.70	5.04	4.50	4.35	4.17
14					6.45	5.70	5.16	4.86	4.65
16						6.36	5.76	5.52	5.19

## 78 Deg. Wet Bulb

APPROACH	R A N G O								
	6	8	10	12	15	20	26	30	35
5	5.04	4.38	3.87	3.57	3.21	2.97	2.70	2.67	2.52
6	5.70	4.95	4.32	3.99	3.60	3.27	2.97	2.91	2.76
7	6.36	5.52	4.80	4.38	3.93	3.60	3.27	3.15	2.97
8		6.00	5.28	4.80	4.32	3.90	3.57	3.45	3.21
10			6.24	5.67	5.07	4.50	4.11	3.93	3.75
12				6.60	5.85	5.19	4.65	4.47	4.26
14					6.60	5.85	5.25	5.04	4.74
16						6.60	5.85	5.64	5.28

## 79 Deg. Wet Bulb

APPROACH	R A N G O								
	6	8	10	12	15	20	26	30	35
5	5.10	4.44	3.93	3.69	3.36	3.00	2.82	2.70	2.58
6	5.79	5.04	4.41	4.11	3.75	3.36	3.09	2.94	2.88
7	6.51	5.55	4.89	4.50	4.11	3.69	3.42	3.21	3.09
8		6.15	5.40	4.92	4.44	3.96	3.69	3.51	3.39
10			6.36	5.85	5.25	4.59	4.26	4.02	3.90
12				6.75	6.00	5.25	4.80	4.59	4.38
14						5.94	5.46	5.16	4.92
16							6.75	6.00	5.79

## 80 Deg. Wet Bulb

APPROACH	R A N G O								
	6	8	10	12	15	20	26	30	35
5	5.28	4.50	4.11	3.78	3.45	3.09	2.85	2.79	2.70
6	6.00	5.10	4.56	4.20	3.81	3.48	3.15	3.03	2.94
7	6.75	5.70	5.10	4.65	4.20	3.78	3.45	3.33	3.21
8		6.24	5.61	5.10	4.56	4.14	3.75	3.63	3.51
10			6.60	6.00	5.40	4.74	4.35	4.14	3.99
12				6.15	5.46	4.92	4.68	4.50	4.38
14					6.09	5.55	5.34	5.10	4.92
16						6.15	5.85	5.64	5.46

## 81 Deg. Wet Bulb

APPROACH	R A N G O								
	6	8	10	12	15	20	26	30	35
5	5.49	4.65	4.20	3.84	3.54	3.21	2.94	2.85	2.73
6	6.15	5.31	4.62	4.32	3.96	3.57	3.24	3.18	3.00
7	6.90	5.88	5.16	4.74	4.32	3.90	3.57	3.48	3.30
8		6.54	5.70	5.16	4.71	4.26	3.81	3.75	3.60
10			6.75	6.15	5.49	4.89	4.41	4.29	4.08
12				6.36	5.61	5.04	4.86	4.65	4.45
14					6.36	5.70	5.49	5.16	4.92
16						6.36	6.09	5.79	5.52

## 82 Deg. Wet Bulb

APPROACH	R A N G O								
	6	8	10	12	15	20	26	30	35
5	5.55	4.74	4.26	3.96	3.60	3.20	3.03	2.94	2.85
6	6.33	5.40	4.74	4.44	3.99	3.63	3.36	3.21	3.09
7		6.00	5.28	4.89	4.38	3.93	3.69	3.54	3.42
8		6.60	5.79	5.40	4.77	4.29	3.96	3.81	3.63
10			6.90	6.30	5.64	5.01	4.56	4.35	4.20
12				6.45	5.70	5.25	5.04	4.74	4.56
14					6.45	5.85	5.64	5.34	5.16
16						6.60	6.21	5.94	5.64

## Section B: CAPACITY TABLES      GPM

### SELECTION FACTORS

MODEL	2.4	2.8	3.2	3.6	4	4.4	4.8	5	5.4	5.8	6.2	6.6
303115	36	42	48	54	60	66	72	75	81	87	93	99
303102	39	46	52	59	65	72	78	81	88	94	101	107
404103	65	75	86	97	108	118	129	134	145	156	167	177
404105	80	93	106	119	133	146	159	166	179	192	205	219
505103	92	107	122	137	153	168	183	191	206	221	236	252
505105	113	131	150	169	188	206	225	234	253	272	291	309
606105	135	158	180	203	225	248	270	281	304	326	349	371
606175	161	187	214	241	268	294	321	334	361	388	415	441
707175	212	247	282	317	353	388	423	441	476	511	546	582
707110	233	271	310	349	388	426	465	484	523	562	601	639
708175	228	266	304	342	380	418	456	475	513	551	589	627
708110	254	296	338	380	423	465	507	528	570	613	655	697
708115	288	336	384	432	480	528	576	600	648	696	744	792
709175	245	285	326	367	408	448	489	509	550	591	632	672
709110	276	322	368	414	460	506	552	575	621	667	713	759
709115	308	359	410	461	513	564	615	641	692	743	794	846
808175	257	299	342	385	428	470	513	534	577	620	663	705
808110	285	333	380	428	475	523	570	594	641	689	736	784
808115	315	368	420	473	525	578	630	656	709	761	814	866
809175	281	327	374	421	468	514	561	584	631	678	725	771
809110	305	355	406	457	508	558	609	634	685	736	787	837
809115	344	401	458	515	573	630	687	716	773	830	887	945
810110	315	368	420	473	525	578	630	656	709	761	814	866
810115	365	425	486	547	608	668	729	759	820	881	942	1002
810120	399	466	532	599	665	732	798	831	898	964	1031	1097
811115	377	439	502	565	628	690	753	784	847	910	973	1035
811120	417	487	556	626	695	765	834	869	938	1008	1077	1147
812115	401	467	534	601	668	734	801	834	901	968	1035	1101
812120	437	509	582	655	728	800	873	909	982	1055	1128	1200
812125	470	548	626	704	783	861	939	978	1056	1135	1213	1291
714275	422	492	562	632	703	773	843	878	948	1019	1089	1159
714210	467	544	622	700	778	855	933	972	1050	1127	1205	1283
816275	513	599	684	770	855	941	1026	1069	1154	1240	1325	1411
816210	570	665	760	855	950	1045	1140	1188	1283	1378	1473	1568
816215	630	735	840	945	1050	1155	1260	1313	1418	1523	1628	1733
1414475	848	989	1130	1271	1413	1554	1695	1766	1907	2048	2189	2331
1414410	933	1089	1244	1400	1555	1711	1866	1944	2099	2255	2410	2566
1616475	1028	1199	1370	1541	1713	1884	2055	2141	2312	2483	2654	2826
1616410	1140	1330	1520	1710	1900	2090	2280	2375	2565	2755	2945	3135
1616415	1260	1470	1680	1890	2100	2310	2520	2625	2835	3045	3255	3465

# GHRFG SERIES SPECIFICATIONS

## 1. GENERAL

Furnish and install an induced draft, counter flow, factory assembled, All-Fiberglass Reinforced Polyester (FRP) casing and structure Cooling Tower(s) of \_\_\_\_\_ cells, as shown on plans. Tower shall be similar and equal in all respects to REYMSA GHRFG model \_\_\_\_\_.

## 2. PERFORMANCE

The tower shall have the capacity to cool \_\_\_\_\_ GPM of water, from \_\_\_\_\_ °F Entering Water Temperature, to \_\_\_\_\_°F leaving water temperature, at a design entering air wet-bulb temperature of \_\_\_\_\_ °F the performance shall be certified by the Cooling Tower Institute (CTI) in accordance with CTI Certification Standard STD-201. Additionally, the Cooling Tower manufacturer shall guarantee the performance of each cell as installed according to plans.

## 3. CONSTRUCTION

The entire casing and structure shall be constructed of Fiberglass Reinforced Polyester (FRP). Only a high grade isophalic polyester resin with UV inhibitor shall be used in the manufacturing process. For One and Two Fan units, the entire body and basin shall be constructed in one-piece, seamless, watertight FRP. No side fasteners will be allowed at the sidewalls of the body or the basin. There shall not be any metal support or structure in direct contact with water. For the one and two Fan units, there shall be one or two independent fan cylinders with a motor support to be constructed completely of FRP, no metal motor support shall be allowed; to be mounted on top of the body structure held in place with stainless steel fasteners provided by the manufacturer, no gasket shall be required, and shall include a corrosion resistant protective mesh screen cover to prevent airborne objects into the fan. The Four Fan units shall consist of three sections; the body shall be constituted by two independent, seamless, watertight FRP pieces, held together with stainless steel fasteners on the sides, provided by the manufacturer. The basin shall be constituted by two independent, seamless, watertight FRP pieces, held together by side stainless steel fasteners provided by the manufacturer. Multi-piece walls or sheet metal wall sections will not be allowed. There shall not be any metal support or structure in direct contact with water. The fan cylinder structure shall have a motor support constructed completely of FRP. No metal supports shall be allowed. All three sections shall be held together by perimetral flanges with stainless steel fasteners provided by the manufacturer, no gasket shall be required. The entire One, Two or Four Fan tower shall be designed and constructed to withstand wind pressure of no less than 30 pounds-force per square foot (psf) on external surfaces. The top of the body shall be designed and constructed to withstand a live load of no less than 40 psf in addition to the concentrated loads of the fan or other equipment mounted thereon. The One, Two and Four Fan unit basin shall be equipped with cold water outlet, drain with mesh screen cover, overflow, water make-up, drain equalizer and purge fittings. All drain fittings 3" and smaller shall be NPT and larger than 3" shall be ANSI flange (FRP or PVC). A bottom sump drain shall be available for dry sump installation, if required.

## 4. FILL, DRIFT ELIMINATOR AND LOUVERS

Fill shall be cross corrugated film-type, thermoformed PVC, in sections not to exceed 1' x 1' x 6'. For hot water temperatures higher than 130°F, Aluminum or Polystyrene fill may be used, as applicable. For Higher water temperatures, drift eliminators shall be thermoformed PVC, in sections not to exceed 1' x 1/2' x 6'. Drift losses shall not exceed 0.005% of the design circulating flow. Louvers shall be thermoformed PVC on all four sides of the tower(s).

## 5. HOT WATER DISTRIBUTION SYSTEM

The hot water shall enter the body through a single inlet per cell. All interior distribution piping shall be PVC, for industrial applications for higher water temperature, fiberglass or Stainless steel piping may be used as applicable. Water shall be evenly distributed over the fill media by a removable, interchangeable ABS (2 1/2") Spray Nozzles. Nozzles shall each contain internal, interchangeable flow devices to provide an optimal spray pattern with 2 to 10 psig pressure differential.

## 6. FANS

Fan(s) shall be propeller type, fan blades shall be constructed with Fiberglass Reinforced Polyamide, spark and corrosive resistant with adjustable pitch suitable for high temperature operation up to 250°F. Hub(s) shall be aluminum alloy castings. Fan(s) shall be directly driven. Towers utilizing gear reducers or belt driven units will not be accepted.

## 7. MOTORS

There shall be single speed, Totally Enclosed Fan Cooled (TEFC), phase, Hertz, volts. Electric Motor(s), NEMA rated for continued operation at a 1.15 service factor. Each motor shall be horsepower for a total Horsepower at RPM.

## 8. MANUFACTURER

The Cooling Tower shall be manufactured by REYMSA COOLING TOWERS, INC



## REYMSA COOLING TOWERS, INC.

1641 World Trade Center, Millenium Industrial Park Laredo, Tx. 78045  
Phone (210) 579-4837 Fax (210) 745-1513

Toll Free Number 1-866-445-2043

sales@reymosa.com www.reymosa.com