



The *All-Fiberglass* Cooling Towers

Installation, Operation & Maintenance Manual



**Tower
Series**



HRFG

LSFG-8

SLSFG-10

INTRODUCTION

Thank you for choosing REYMSA Cooling Towers as your best Fiberglass Cooling Tower option.

Since 1969, REYMSA Cooling Towers has been providing cost effective heat transfer solutions for the HVAC, industrial and plastic markets, having more than 5000 installed Cooling Towers around the world. REYMSA's towers are manufactured with high quality materials and are designed to provide years of reliable service when properly operated and maintained.

The following manual has been prepared to support our customers with the installation and maintenance process of the "state of the art" (HRFG) Series towers and the Low Sound & Super Low Sound (LSFG & SLSFG) Series towers. Our Installation, Operation & Maintenance manual (IOM) has been written and reviewed by our engineering department based on theoretical knowledge and practical experience. A recommended guide is included for the start-up process assuring a secure and optimized installation. Regarding maintenance, REYMSA Cooling Towers strongly recommends establishing a scheduled maintenance program and ensure it is followed; this manual could be used as a guide to establish it.

It is highly recommended that the whole manual and warranty are read before the installation and start-up.

If you have any doubts or need additional information, please contact your local REYMSA Cooling Towers representative or visit our website.

www.reymsa.com

TABLE OF CONTENTS

A. INSTALLATION	1
A.1. LOCATION	1
A.1.1. RECIRCULATION AND INTERFERENCE	1
A.1.2. ENVIRONMENTAL AND SAFETY	2
A.2. ASSEMBLY INSTRUCTIONS	3
A.2.1. SINGLE FAN TOWERS	3
A.2.2. DOUBLE FAN TOWERS	5
A.2.3. QUADRUPLE FAN TOWERS	7
A.2.4. MODULAR TOWERS	10
A.2.5. LOW SOUND COOLING TOWERS: FAN ADAPTORS	16
A.2.6. MULTIPLE TOWERS	18
A.2.7. BOTTOM OUTLET CONNECTION	18
A.2.8. OPTIONAL ACCESSORIES	19
A.2.8.1. ACCESSORIES - SAFETY	19
A.2.8.2. VIBRATION SWITCH	21
A.2.8.3. BASIN HEATER	23
A.2.8.4. ELECTRIC WATER LEVEL CONTROL SYSTEM	24
A.3. TOWER SET-UP	27
A.3.1. LEVELING AND TOWER SUPPORTS	27
A.3.2. PIPING CONNECTIONS	27
A.3.3. WIRING	30
B. START-UP	33
B.1. FILLING SYSTEM WITH WATER	33
B.2. CONTROLLING WATER LEVEL	33
B.3. PUMP	33
B.4. FAN	34
C. OPERATION	35
C.1. WATER DISTRIBUTION SYSTEM	35
C.2. WATER TREATMENT	36
C.2.1. SUSPENDED SOLIDS	36
C.2.2. SCALE FORMATION	37
C.2.3. BIOLOGICAL GROWTHS	37
C.3. MAKE-UP WATER REQUIREMENTS	37
C.4. COLD WEATHER OPERATION	38
C.5. SEASONAL SHUT-DOWN	39
D. MAINTENANCE	40
D.1. TOWER MAINTENANCE SCHEDULE	41
D.2. BASIN	42
D.3. TOWER BODY	43
D.4. FAN AND MOTOR	44
E. TROUBLE-SHOOTING	45
APPENDIX	47
APPENDIX A: PHOTOGRAPHIC SEQUENCE - SINGLE FAN TOWER INSTALLATION	47
APPENDIX B: PHOTOGRAPHIC SEQUENCE - DOUBLE FAN TOWER INSTALLATION	48
APPENDIX C: PHOTOGRAPHIC SEQUENCE - QUADRUPLE FAN TOWER INSTALLATION	49
APPENDIX D: PHOTOGRAPHIC SEQUENCE - MODULAR TOWER INSTALLATION	50
APPENDIX E: EXAMPLE OF STRUCTURAL BASE FOR A REYMSA COOLING TOWER	52
APPENDIX F: EXAMPLES OF ACCESSORIES ASSEMBLY INSTRUCTIONS	53
APPENDIX G: MINIMUM DISTANCES BETWEEN TOWERS AND OBSTRUCTIONS	55
APPENDIX H: WATER MAKE-UP FLOAT VALVE	56
TABLES	
Table A-1: Minimum recommended distance between towers and obstructions	1
Table A-2: Receiving flange type (single fan towers)	4
Table A-3: Receiving flange type (double fan towers)	6
Table A-4: Receiving flange type (quadruple fan towers)	9
Table A-5: Equalizer connection sizes	18
Table C-1: Maximum operating temperatures for different fill media materials	35
Table C-2: Water chemistry guidelines	36
Table C-3: Water usage	38
Table D-1: Recommended maintenance schedule	41
FIGURES	
Figure A-1 : Minimum recommended distance between towers and obstructions	1
Figure A-2: Recirculation	2
Figure A-3: Single fan tower fork lifting	3
Figure A-4: Single fan tower crane Lifting	3
Figure A-5: Fan duct lifting	3

Figure A-6: Installation - Typical anchorage for a single fan tower	3
Figure A-7: Fan duct Installation for single fan tower	4
Figure A-8: Fan duct alignment	4
Figure A-9: Double fan tower fork lifting	5
Figure A-10: Double fan tower crane lifting	5
Figure A-11: Fan duct lifting	5
Figure A-12: Installation - Typical anchorage for double fan tower	5
Figure A-13: Fan duct 1 installation - double fan tower	6
Figure A-14: Fan duct alignment	6
Figure A-15: Handling tower section 1 - quadruple fan tower	7
Figure A-16: Fan duct lifting	7
Figure A-17: Tower section 1 installation for a quadruple fan tower	7
Figure A-18: Installation - Typical anchorage for quadruple fan tower	8
Figure A-19: Tower sections 1 & 2 installation for a quadruple fan tower	8
Figure A-20: Fan duct 1 Installation for quadruple fan tower	9
Figure A-21: Fan duct alignment	9
Figure A-22: Modular tower handling	10
Figure A-23: Basin section 1 installation	10
Figure A-24: Typical anchorage for a modular tower	11
Figure A-25: Basin section installation	11
Figure A-26: Upper air inlet section 1 installation	11
Figure A-27: Upper air inlet sections installation	12
Figure A-28: Tower body section 1 installation	12
Figure A-29: Tower body section installation	13
Figure A-30: Tower cover section 1 installation	13
Figure A-31: Tower cover section installation	14
Figure A-32: Fan duct 1 Installation	14
Figure A-33: Fan duct alignment	15
Figure A-34: Fan sections installation	15
Figure A-35: Fan adaptor in single fan tower	16
Figure A-36: Fan adaptor Installation	16
Figure A-37: Fan adaptor alignment	16
Figure A-38: Fan adaptor 2 Installation	17
Figure A-39: Fan duct installation in a fan adaptor	17
Figure A-40: Fan duct alignment	17
Figure A-41: Fan duct Installation in a fan adaptor for a quadruple fan tower	17
Figure A-42: Equalizer line installation	18
Figure A-43: Bottom outlet connection detail	18
Figure A-44: Bottom outlet connection	18
Figure A-45: Tightening sequence	19
Figure A-46: Optional accessories by REYMSA	19
Figure A-47: Optional safety accessories	20
Figure A-48: Vibration switch recommended location	21
Figure A-49: Internal switches	21
Figure A-50: Typical electrical diagram	21
Figure A-51: Vibration switch detail	22
Figure A-52: Sensitivity adjustment	22
Figure A-53: Basin heater system	23
Figure A-54: Recommended basin heater mounting	23
Figure A-55: Basin heater control panel diagram	24
Figure A-56: Water level control system	24
Figure A-57: Water level control parts	25
Figure A-58: Water level and alarm controls diagram	26
Figure A-59: Example of structural base	27
Figure A-60: Single fan cooling tower - pipe Connections	28
Figure A-61: Double fan cooling tower - pipe Connections	28
Figure A-62: Quadruple fan cooling tower - pipe Connections	29
Figure A-63: Example of equalization line	30
Figure B-1: Float valve installation	33
Figure C-1: Water distribution system schematic	35
Figure C-2: Filtration system	36
Figure C-3: Fan duct covering	39
Figure AP-1: Float valve installed in a cooling tower	56
Figure AP-2: Copper float	56
Figure AP-3: Plastic float	56
Figure AP-4: Example of valves	56
Figure AP-5: Example of stems	56



INSTALLATION, OPERATION & MAINTENANCE MANUAL
Standard (HRFG Series)
Low Sound (LSFG-8 & SLSFG-10 Series)

A. INSTALLATION

A.1. LOCATION

Location of the cooling tower is important to assure it achieves its desired performance. A bad location choice could lead to performance, safety and environmental issues. The following considerations are meant to be a guideline to avoid such problems.

A.1.1. RECIRCULATION AND INTERFERENCE

Recirculation is the recapture of a portion of warm and humid air by the same tower. Interference is caused when a cooling tower is situated downwind or in close proximity to a heat-emitting source, like another cooling tower, fired heaters, flare stacks, boilers, etc. and warm air enter the cooling tower. Both phenomena causes a variation in the entering air wet bulb temperature, therefore affecting the cooling tower performance. To avoid recirculation and interference, consider the following guidelines:

- Remove any obstructions that might prevent the free flow of the exiting air.
- Make sure that the area provides enough clearance for safe operation. Place towers far enough apart so that discharge air from one tower is not drawn in by another. See Table A-1 and Figure A-1 for recommended minimum distances between towers and between a tower and a wall.

Table A-1 & Figure A-1: Minimum recommended distance between towers and obstructions

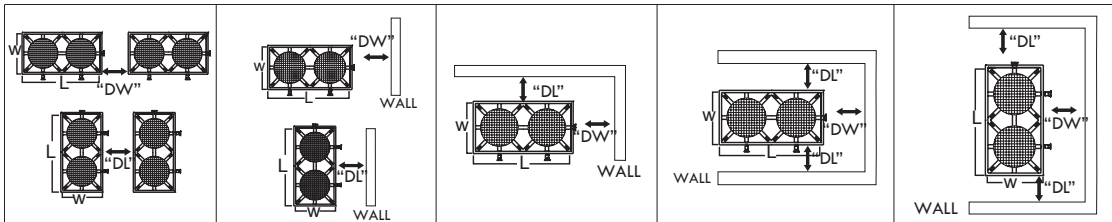

MODEL	BETWEEN TOWERS		ONE WALL		TWO WALLS		THREE WALLS (A)		THREE WALLS (B)	
	SHORT SIDE "DW"	LONG SIDE "DL"	SHORT SIDE "DW"	LONG SIDE "DL"	SHORT SIDE "DW"	LONG SIDE "DL"	SHORT SIDE "DW"	LONG SIDE "DL"	SHORT SIDE "DW"	LONG SIDE "DL"
HRFG-303	6	6	3	3	3	3	3	3	3	3
HRFG-404	6	6	3	3	3	3	3	3	3	3
HRFG-505	6	6	3	3	3	3	3	3	3	3
HRFG-606	6	6	3	3	3	3	3	3	3	3
HRFG-707	6	6	3	3	3	3	4	3	4	3
HRFG-708	6	6	3	3	3	3	4	3	4	3
HRFG-709	6	6	3	3	3	3	4	3	4	3
HRFG-808	6	6	3	3	3	3	4	3	4	3
HRFG-809	6	6	3	3	3	3	4	3	4	3
HRFG-810	6	6	3	3	3	4	5	4	5	3
HRFG-811	6	6	3	3	4	4	5	4	5	4
HRFG-812	6	6	3	3	4	4	5	4	5	4
HRFG-714	6	7	3	4	4	4	5	4	5	4
HRFG-816	6	7	3	4	4	4	5	4	5	4
HRFG-822	6	7	3	4	3	5	5	5	5	3
HRFG-827	6	8	3	4	4	5	5	5	5	4
HRFG-1414	9	9	5	5	6	5	7	5	6	6
HRFG-1616	11	10	6	5	6	6	8	6	7	6
HRFG-1622	10	12	5	6	6	7	8	7	8	6
HRFG-1627	11	12	6	6	7	7	8	7	8	7

For the low sound & super low sound table of minimum distances between towers and obstructions please refer to APPENDIX G.



- Place the cooling tower in a position where it will have at least the recommended clearance on all sides for servicing and adequate air intake. It is advisable and preferred to have the top of the tower above the roofline of any adjacent buildings or other nearby obstructions. This will limit the possibilities of the air recirculation back into the towers air intake (See Figure A-2).

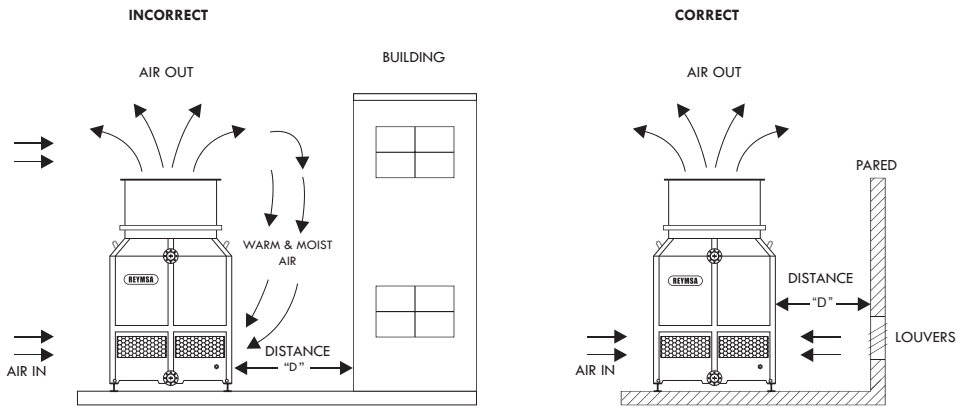

Figure A-2: Recirculation

- Use prevailing summer winds as a guideline for placing a tower in a location that minimizes interference.
- Do not place cooling towers near exhaust fans or air intakes.
- Do not place the cooling tower near air make-up units where there is a possibility of the moist tower discharge air mixing with the air being drawn in by it.

A.1.2. ENVIRONMENTAL AND SAFETY

- Cooling tower must be installed in accordance to all applicable construction, electrical and safety standards as well as State and Local codes and regulations.
- Make sure the area provides a grounded power source supplying the correct electric current for the cooling tower. Field wiring should be completed by qualified personnel to the planned location for the cooling tower. All electrical wiring should comply with electrical codes. Also see section A.3.3, for proper wiring.
- Place the cooling tower on a leveled structural surface, capable of supporting the operational weight of the tower. Refer to section A.3.1 of this manual for information about leveling and recommended support. Contact your REYMSA Representative about any doubts regarding the recommended support for the cooling tower.
- REYMSA Cooling Towers are industrial pieces of equipment with rotating parts. Care should be taken in placing them in a secure area where unauthorized access is minimized.
- Locate tower where there is a safe access for its maintenance.
- Cooling tower must be installed in a location where tower's discharged air cannot be drawn into any surrounding building fresh-air ducts.
- There is a certain amount of water that can be carried over in the discharge air of all cooling towers (drift). Consideration should be given to placing cooling towers away from high traffic areas such as entrances and parking lots.

A.2. ASSEMBLY INSTRUCTIONS

A.2.1. SINGLE FAN TOWERS

Follow this procedure to assembly and install Single fan cooling towers; also refer to Appendix A, where is shown a photographic sequence of the installation of a Single fan tower.

A. Upon the arrival of the equipment to its final destination, check for any abnormality or apparent damage on the packaging before unloading the cooling tower from the transportation vehicle. Any equipment absences or abnormality must be reported with your local REYMSA representative.

B. After assuring the equipment is received in proper conditions, proceed to unload it from the transportation vehicle, piece by piece, with a crane or forklift of the appropriate capacity (see Figure A-3, Figure A-4 and Figure A-5 for examples). For crane lifting, it's recommended to use a minimum lifting angle of 60° between the strap and the horizontal.

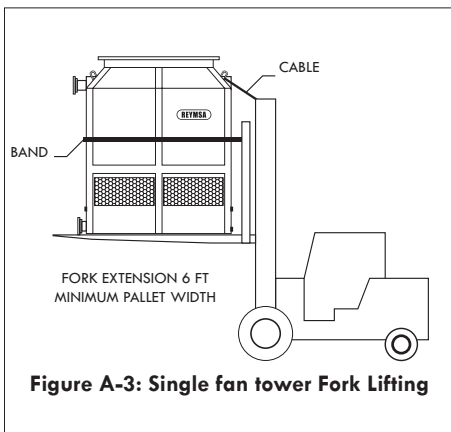

Figure A-3: Single fan tower Fork Lifting

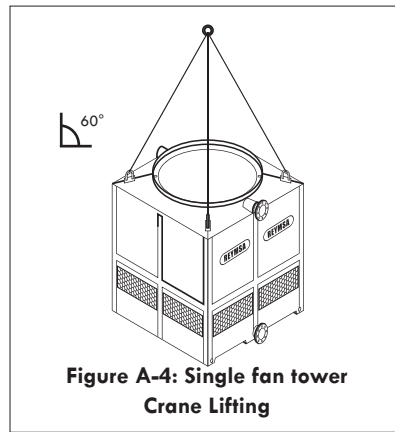

Figure A-4: Single fan tower Crane Lifting

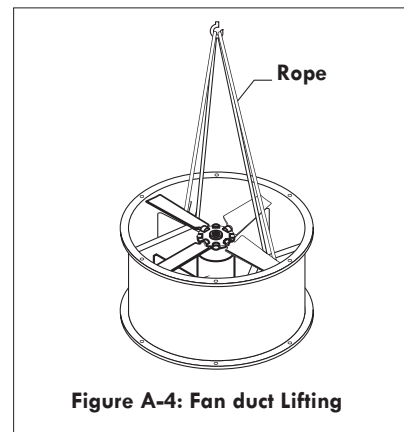

Figure A-4: Fan duct Lifting

C. Remove the plastic wrap that surround the tower and its components, and loosen the nuts and bolts that keep the unitized body & basin attached to the wooden pallet (those located at the bottom of basin).

D. Before installing the tower, make sure that the structure will support the tower's operational weight; also place an isolation pad (supplied by others) between the tower and the base for support purposes. Verify that the support has the proper dimensions (for construction purposes, refer to factory certified drawings). See section A.3.1, "Leveling and tower support", for more information.

E. Place the tower Section (Basin and Body) on top of the isolation pad and the base, making sure that the anchorage holes on the bottom of the tower are aligned with the perforations on the base. Bolt it down and secure it with stainless steel nut and bolt sets (supplied by others, see Figure A-6)

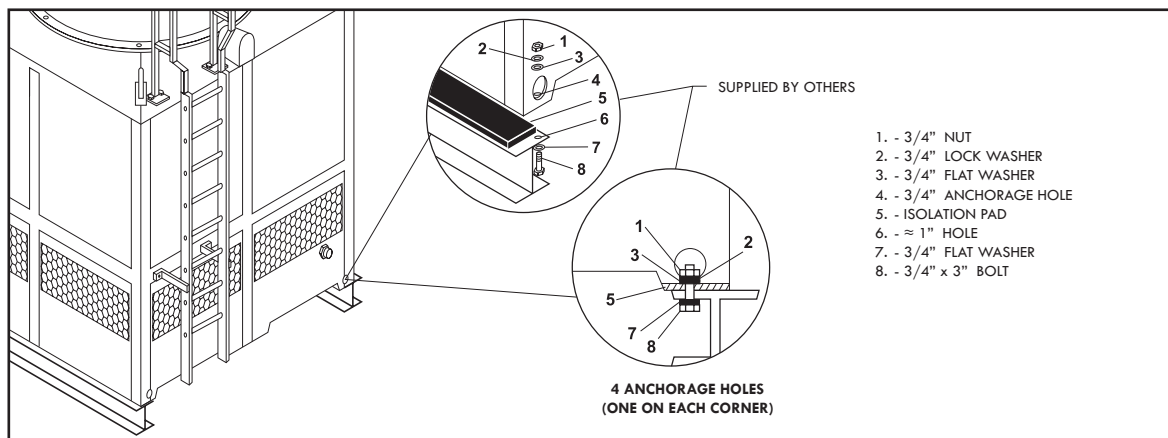
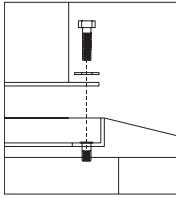

Figure A-6: Installation - Typical anchorage for a single fan tower



F. Now place the fan duct on the receiving flange on top of the tower (see Figure A-7); make sure the bolt holes and the marks inside the fan duct and receiving flange are aligned (see Figure A-8). Secure it with the stainless steel nut and bolt sets supplied by REYMSA.

RECESSED FLANGE



ASSEMBLY HOLES

1. 1/2" x 2.5" BOLT
2. 1/2" FLAT WASHER
3. 5/8" HOLE
4. 1/2" INSERT
(ALREADY ASSEMBLED)

EXTERNAL FLANGE

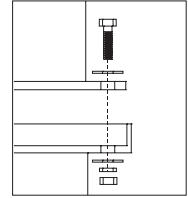

ASSEMBLY HOLES

1. 1/2" x 2.5" BOLT
2. 1/2" FLAT WASHER
3. 5/8" HOLE
4. 1/2" FLAT WASHER
5. 1/2" LOCK WASHER
6. 1/2" NUT

**Table A-2: Receiving flange type
(Single fan tower)**

HRFG SINGLE FAN MODELS	RECEIVING FLANGE
303115 - 303102	RECESSED FLANGE
404103 - 404105	
505103 - 505105	
606105 - 606175	
707175 - 707110	
708175 - 708110 - 708115	
709175 - 709110 - 709115	EXTERNAL FLANGE
808175 - 808110 - 808115	
810110 - 810115 - 810120	
812115 - 812120 - 812125	

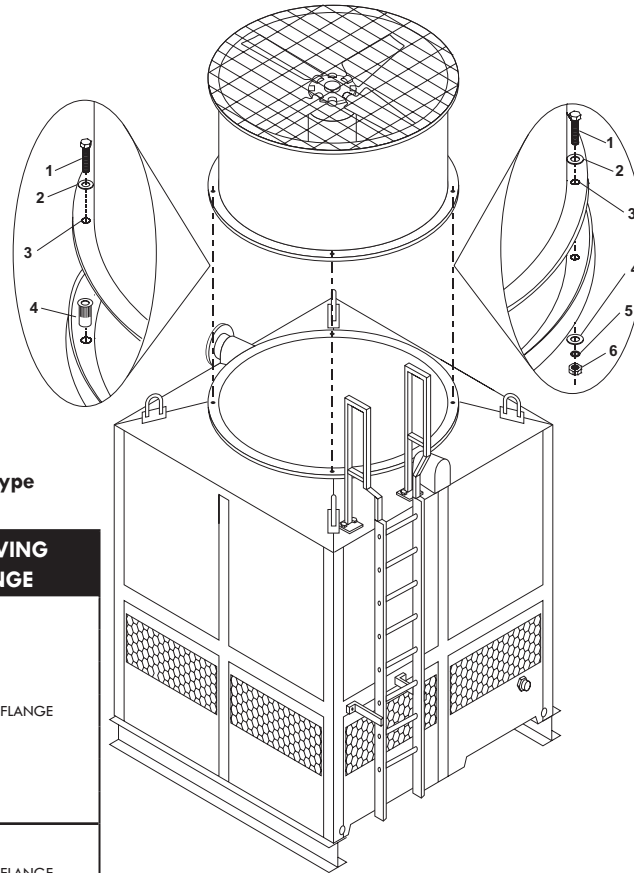

Figure A-7: Fan duct installation for single fan tower

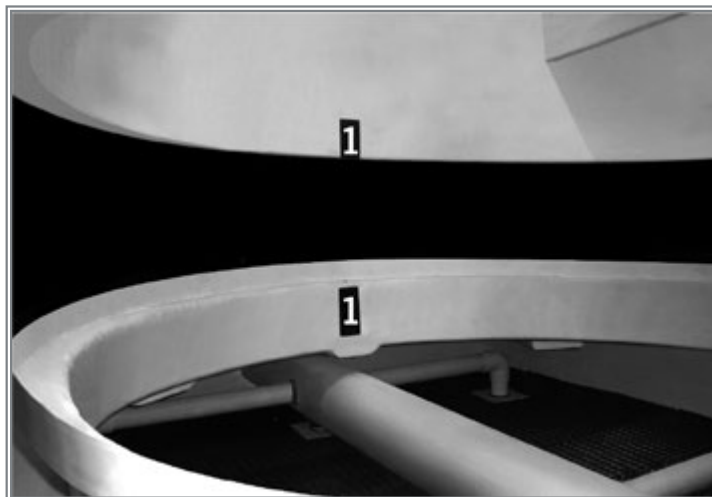
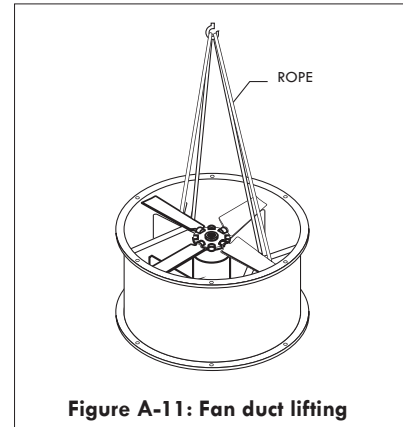
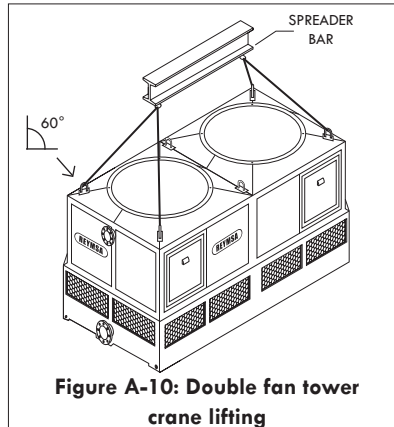
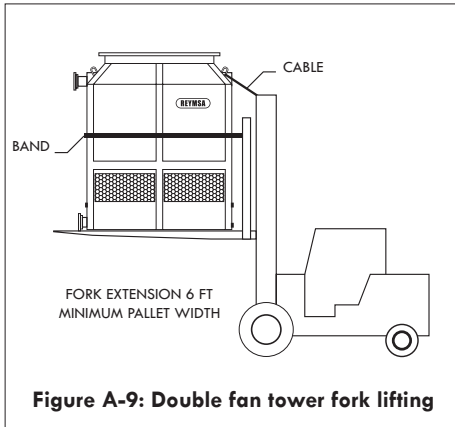

Figure A-8: Fan duct alignment

A.2.2. DOUBLE FAN TOWERS

Follow this procedure to assembly and install double fan cooling towers; also refer to Appendix B, where is shown a photographic sequence of the installation of a double fan tower.

- A. Upon the arrival of the equipment to its final destination, check for any abnormality or apparent damage on the packaging before unloading the cooling tower from the transportation vehicle.
- B. After assuring the equipment is received in proper conditions, proceed to unload it from the transportation vehicle, piece by piece, with a crane (using a spreader bar) or forklift of the appropriate capacity (see Figure A-9, Figure A-10 and Figure A-11 for examples). For crane lifting, it's recommended to use a minimum lifting angle of 60° between the strap and the horizontal.



- C. Remove the plastic wrap that surround the tower and its components, and loosen the nuts and bolts that keep the unitized body & basin attached to the wooden pallet (those located at the bottom of basin).
- D. Before installing the tower, make sure that the structure will support the tower's operational weight; also place an isolation pad (supplied by others) between the tower and the base for support purposes. Verify that such support has the proper dimensions (for construction purposes, refer to factory certified drawings). See section A.3.1, "Leveling and tower support", for more information.
- E. Place the tower section (Basin and Body) on top of the isolation pad and the base, making sure that the anchorage holes on the bottom of the tower are aligned with the perforations on the base. Then proceed to bolt it down and secure it with stainless steel nut and bolt sets (supplied by others, see Figure A-12).

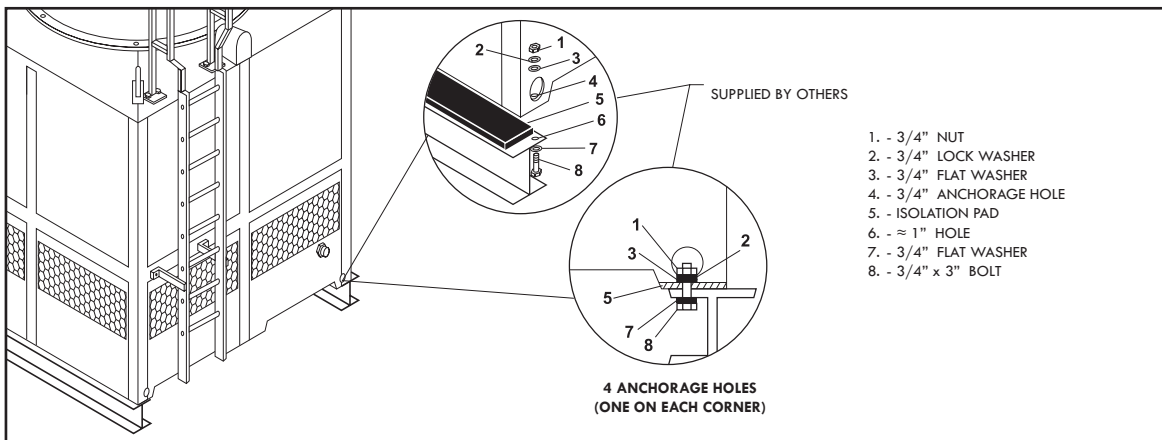

Figure A-12: Typical anchorage for double fan tower



F. Identify each fan duct, they are labeled with a number on the inside of the lower edge; for a correct installation, this number must match the number on the corresponding receiving flange. Now place the fan duct 1 on the receiving flange on top of the tower (see Figure A-13); make sure the bolt holes and the marks inside the fan duct and receiving flange are aligned (Figure A-14). Secure it with the stainless steel nut and bolt sets supplied by REYMSA.

G. Follow the same instructions to place fan duct 2.

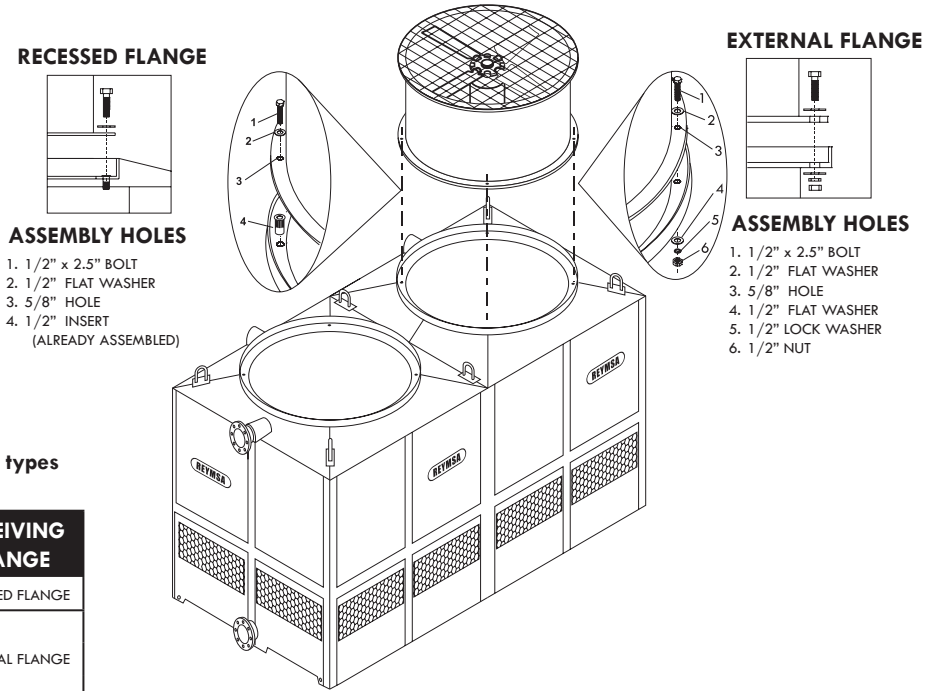

Table A-3: Receiving flanges types (double fan towers)

HRFG DOUBLE FAN MODELS	RECEIVING FLANGE
714275 - 714210	RECESSED FLANGE
816275 - 816210 - 816215	EXTERNAL FLANGE
822215 - 822220	
827215 - 827220	

Figure A-13: Fan duct 1 installation - double fan tower

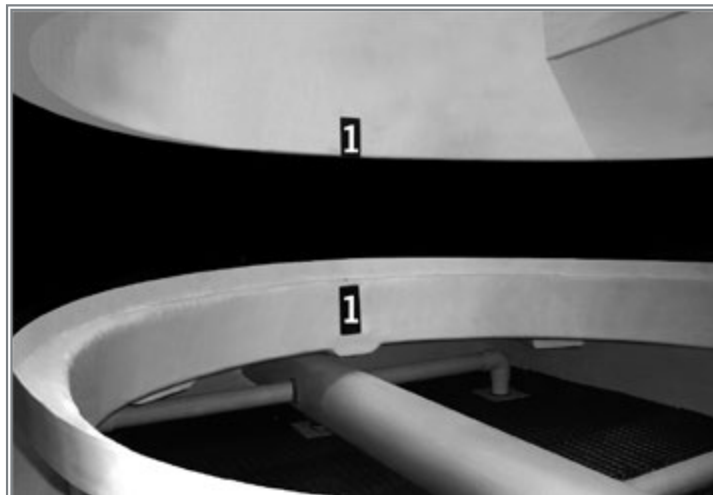

Figure A-14: Fan duct Alignment

A.2.3. QUADRUPLE FAN TOWERS

Follow this procedure to assembly and install quadruple fan cooling towers; also refer to Appendix C, which is a photographic sequence of the Installation of a quadruple fan tower, to gain another perspective of this section.

- A. Upon the arrival of the equipment to its final destination, check for any abnormality or apparent damage on the packaging before unloading the cooling tower from the transportation vehicle.
- B. After assuring the equipment is received in proper conditions, proceed to unload it from the transportation vehicle, piece by piece with a crane (using a spread bar) or forklift of the appropriate capacity. See examples on Figure A-15 and Figure A-16. For crane lifting, it's recommended to use a minimum lifting angle of 60° between the strap and the horizontal.

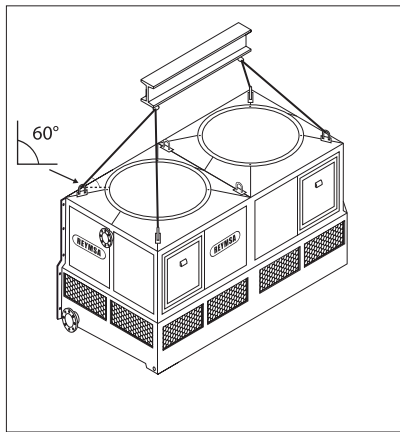

Figure A-15: Handling tower section 1 quadruple fan tower

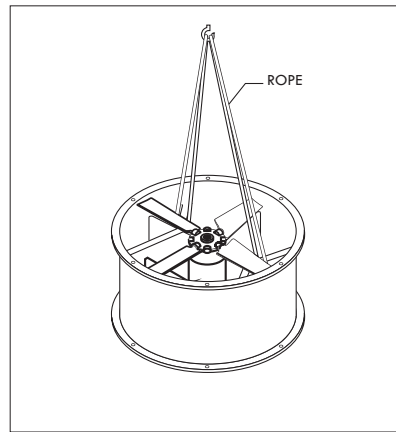

Figure A-16: Fan duct lifting

- C. Remove the plastic wrap that surround the tower and its components, and loosen the nuts and bolts that keep the unitized body & basin attached to the wooden pallet (those located at the bottom of basin).
- D. Before installing the tower, make sure that the structure will support the tower's operational weight; also place an isolation pad (supplied by others) between the tower and the base for support purposes. Verify that such support has the proper dimensions (for construction purposes, refer to factory certified drawings). See section A.3.1, "Leveling and tower support", for more information.
- E. Place tower Section 1 (see Figure A-17) on top of the isolation pad and the base, making sure that the anchorage holes on the bottom of the tower are aligned with the perforations on the base. Bolt it down and secure it with stainless steel nut and bolt sets (supplied by others, see Figure A-18)

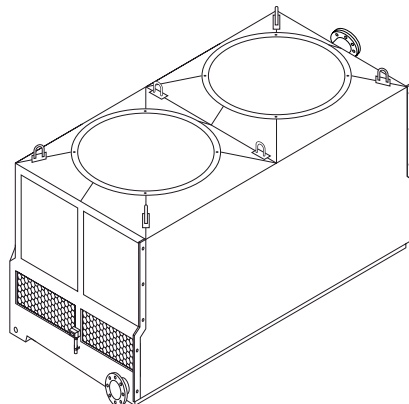
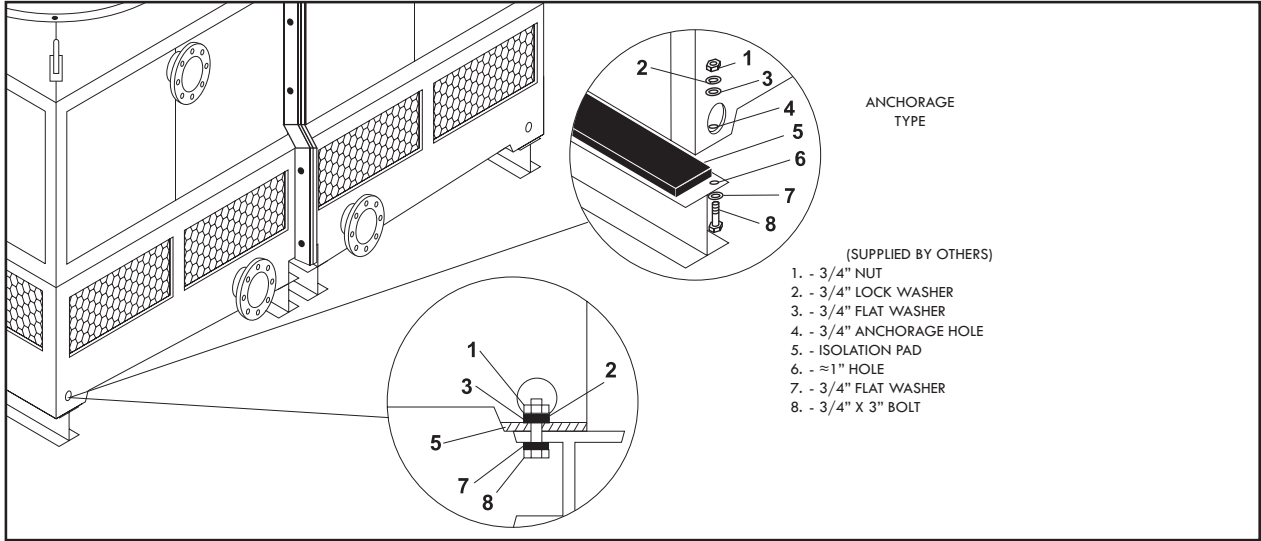

Figure A-17: Tower Section 1 Installation for a quadruple fan tower



A-18: Installation - Typical anchorage for quadruple fan tower

F. Place tower Section 2 on top of structural base, and then proceeds to bolt together the vertical flanges of Sections 1 & 2; use first the galvanized bolts and nuts to join sections (supplied by REYMSA). Then replace the galvanized bolts with the stainless steel nut and bolt sets supplied by REYMSA (see Figure A-19). Then bolt down and secure tower Section 2 to the structural base with stainless steel nut and bolt sets (supplied by others, see Figure A-18)

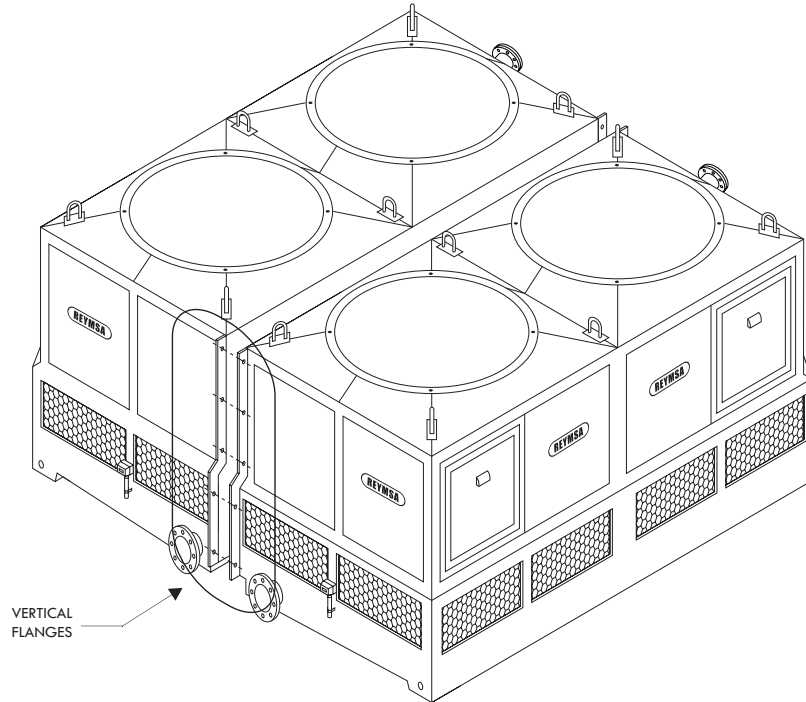
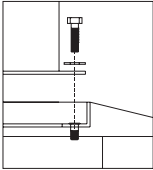

Figure A-19: Tower sections 1 & 2 installation for a quadruple fan tower

G. Identify each fan duct, they are labeled with a number on the inside of the lower edge; for a correct installation, this number must match the number on the corresponding receiving flange. Place fan duct 1 on top of tower Section 1 and secure it along the receiving flange on top of the body section using the stainless steel nut and bolt sets supplied by REYMSA (see Figure A-20); make sure the bolt holes and the marks inside the fan duct and receiving flange are aligned (Figure A-21).

RECESSED FLANGE



ASSEMBLY HOLES

1. 1/2" x 2.5" BOLT
2. 1/2" FLAT WASHER
3. 5/8" HOLE
4. 1/2" INSERT
(ALREADY ASSEMBLED)

EXTERNAL FLANGE

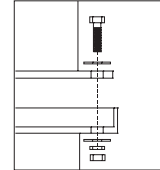

ASSEMBLY HOLES

1. 1/2" x 2.5" BOLT
2. 1/2" FLAT WASHER
3. 5/8" HOLE
4. 1/2" FLAT WASHER
5. 1/2" LOCK WASHER
6. 1/2" NUT

**Table A-4: Receiving flange type
(Quadruple fan tower)**

HRFG QUADRUPLE FAN MODELS	RECEIVING FLANGE
1414475 - 1414410	RECESSED FLANGE
1616475 - 1616410 - 1616415	EXTERNAL FLANGE
1622415 - 1622420	
1627415 - 1627420	

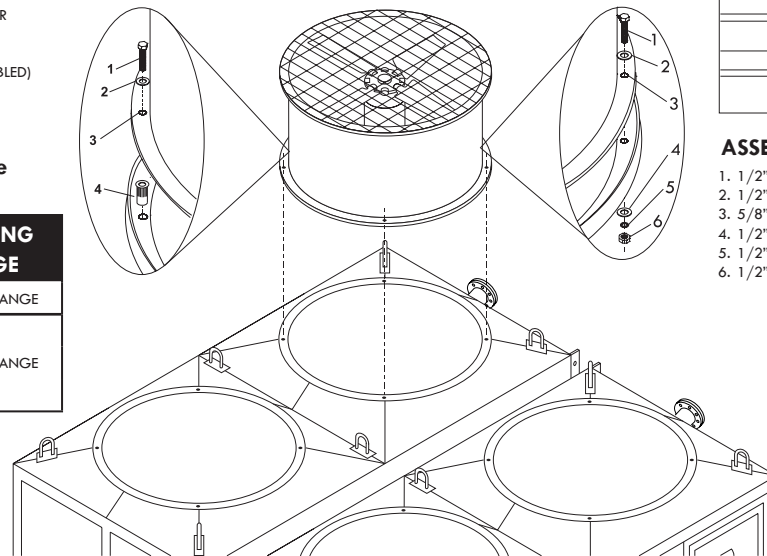

Figure A-20: Fan duct 1 installation for quadruple fan tower



Figure A-21: Fan duct alignment

H. Continue to place fan duct 2 on top of tower Section 1, following the same instructions mentioned on previous step. Follow the same instructions for the remaining fan ducts.



A.2.4. MODULAR TOWERS

Follow this procedure to assembly and install a Modular cooling tower; also refer to Appendix D, a photographic sequence of the installation, to have another perspective of this section. Use drift pins to align bolt holes and use the galvanized bolts provided to torque the sections together. Replace galvanized bolt with stainless bolts after sections are secured together.

- A. Upon the arrival of the equipment to its final destination, check for any abnormality or apparent damage on the packaging before unloading the cooling tower from the transportation vehicle.
- B. After assuring the equipment is received in proper conditions, proceed to unload it from the transportation vehicle, piece by piece, with a crane (using a spread bar) or forklift of the appropriate capacity, see Figure A-22 for an example.

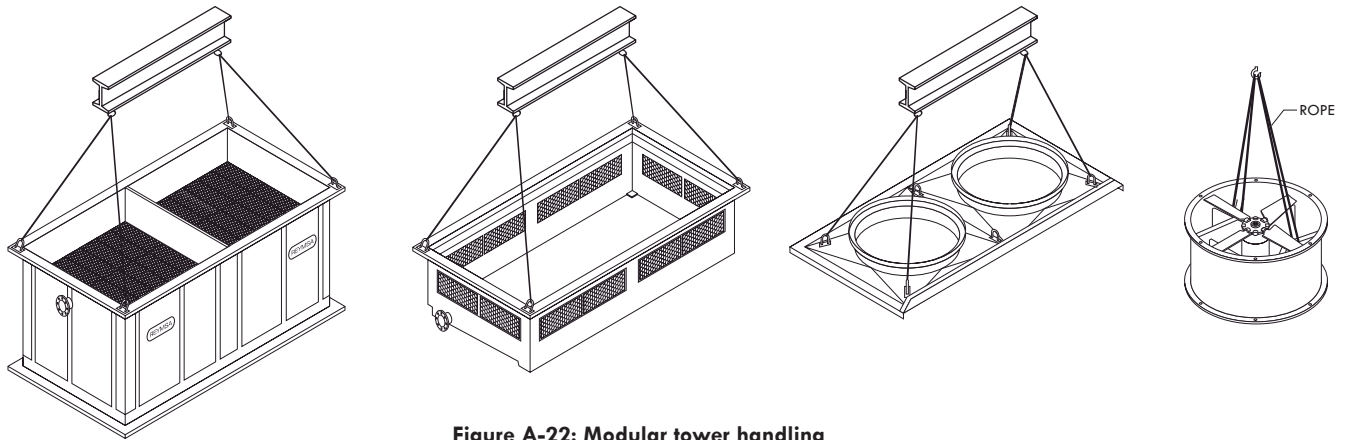

Figure A-22: Modular tower handling

- A. Remove the plastic wrap that surround the tower and its components, and loosen the nuts and bolts that keep the unitized body & basin attached to the wooden pallet (those located at the bottom of basin).
- B. Before installing the tower, make sure that the base structure that will support the tower can withstand the tower's operational weight (refer to unit specifications); also place an isolation pad (supplied by others) between the tower and the base for support purposes. Also verify that such support has the proper dimensions and leveling (for construction purposes, refer to factory certified drawings). See section A.3.1, "Leveling and tower support", for more information.
- C. Identify each sections by the number located inside the tower. The number sequence will install Horizontally (i.e.#1, #2, #3...) while the common numeric's stack vertically (#1 basin, #1 upper inlet, #1 body/fill section, #1 cover, #1 fan duct).
- D. Place Basin Section 1 on top of the structural base, making sure that the anchorage holes on the bottom of the tower are aligned with the perforations on the base (See Figure A-23). Bolt down and secure it with stainless steel nut and bolt sets (supplied by others, refer to Figure A-24).

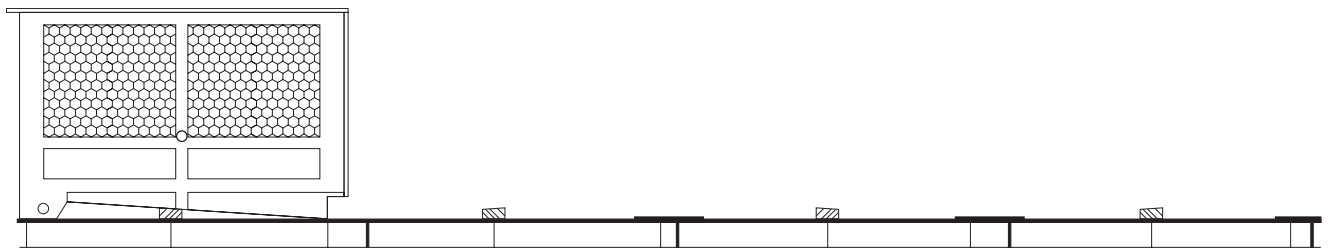

Figure A-23: Basin section 1 installation

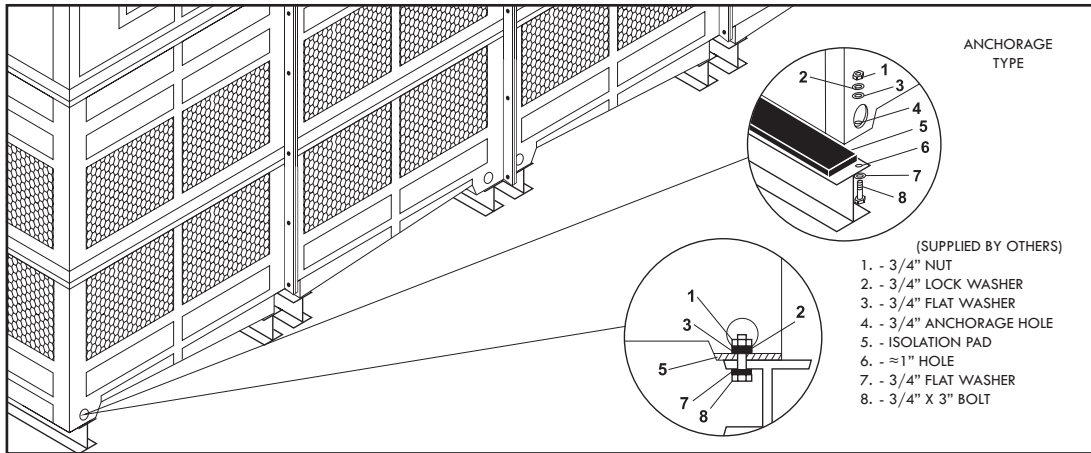

Figure A-24: Typical anchorage for a modular tower

G. Proceed to place Basin Section 2 on top of the isolation pad and the structural base, making sure that the anchorage holes are aligned. Bolt the vertical flanges of Basin Sections 1 & 2 together using first the galvanized steel bolts and nuts (supplied by REYMSA) to join sections. Then replace the galvanized steel bolts with the stainless steel nut and bolt sets supplied by REYMSA. Then proceed to bolt down and secure Basin Section 2 to the structural base with the stainless steel nut and bolt sets supplied by others (see Figure A-24). Repeat until all Basin Sections have been installed (see Figure A-25).

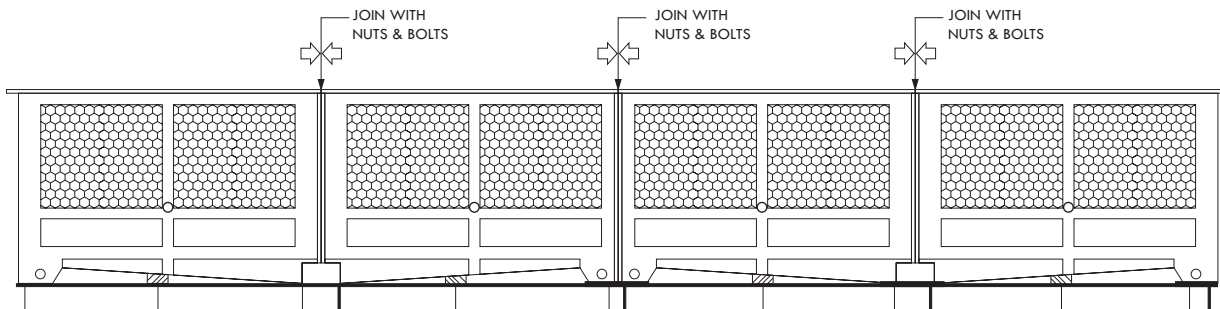

Figure A-25: Basin section installation

H. Place Upper Air Inlet Section 1 on top of Basin Section 1, making sure that the bolt holes on Upper Air Inlet Section 1 are aligned with the perforations on Basin Section 1, then bolt down and secure the horizontal flanges with the stainless steel nut and bolt sets supplied by REYMSA (See Figure A-26)

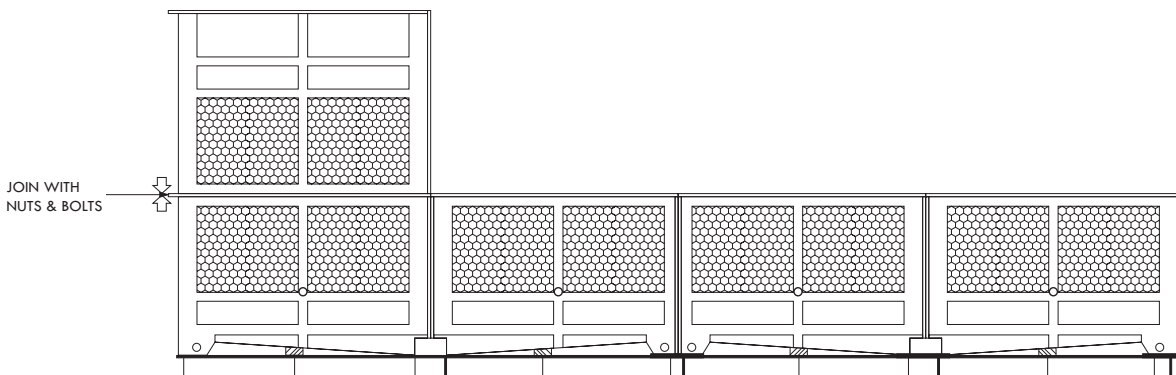

Figure A-26: Upper air inlet section 1 installation

- I. Proceed to place upper air inlet section 2 on top of basin section 2; make sure that the bolt holes are aligned. Bolt the vertical flanges between upper air inlet sections 1 & 2 together using first the galvanized steel bolts and nuts (supplied by REYMSA) to join sections. Then replace the galvanized steel bolts with the stainless steel nut and bolt sets supplied by REYMSA. Then proceed to bolt down and secure the horizontal flanges between upper air inlet section 2 and basin section 2, with the stainless steel nut and bolt sets supplied by REYMSA. Repeat until all upper air inlet sections have been installed (see Figure A-27).

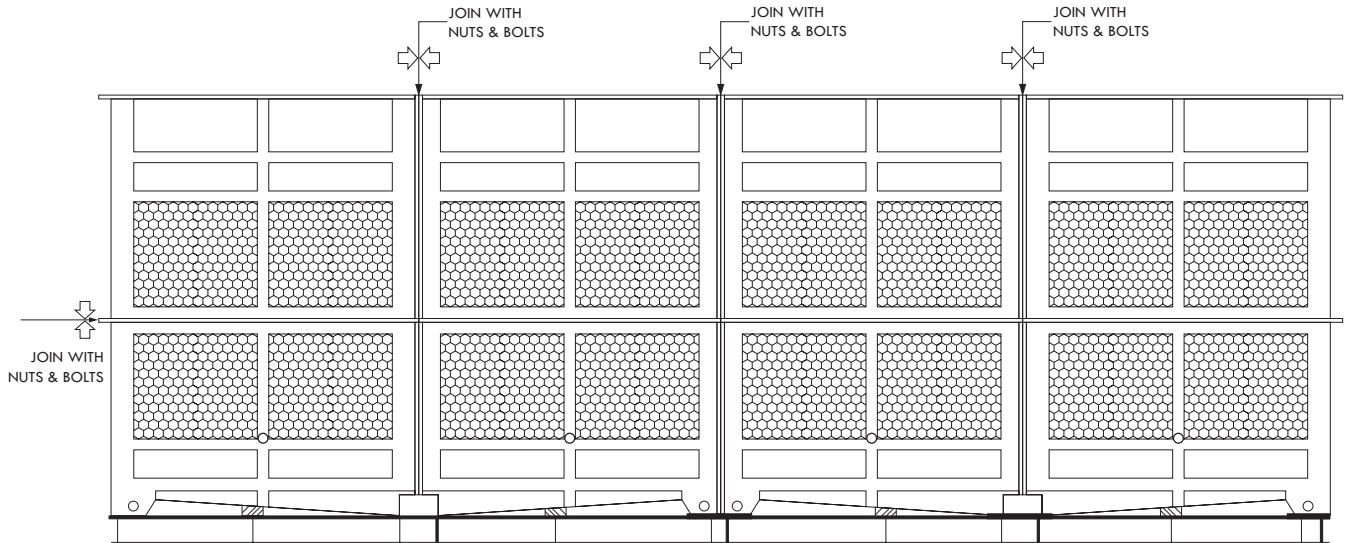

Figure A-27: Upper air inlet sections installation

- J. Place tower body section 1 on top of upper air inlet section 1, making sure that the bolt holes on tower body section 1 are aligned with the perforations on upper air inlet 1, then bolt down and secure the horizontal flanges with the stainless steel nut and bolt sets supplied by REYMSA (see Figure A-28).

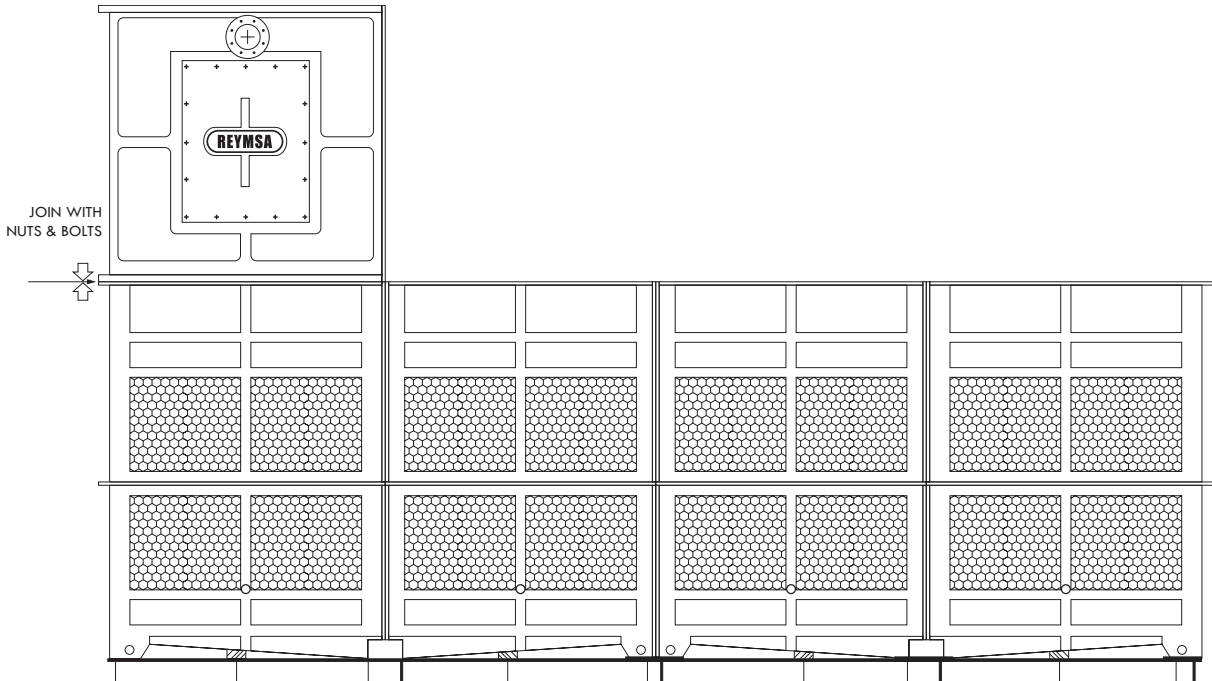

Figure A-28: Tower body section 1 installation

Proceed to place tower Body Section 2 on top of Upper Air Inlet Section 2; make sure that the bolt holes are aligned. Bolt the vertical flanges between tower Body Sections 1 & 2 together using first the galvanized steel bolts and nuts (supplied by REYMSA) to join sections. Then replace the galvanized steel bolts with the stainless steel nut and bolt sets supplied by REYMSA. Then proceed to bolt down and secure the horizontal flanges between tower Body Section 2 and Basin Section 2, with the stainless steel nut and bolt sets supplied by REYMSA. Repeat until all tower Body Sections have been installed (see Figure A-29).

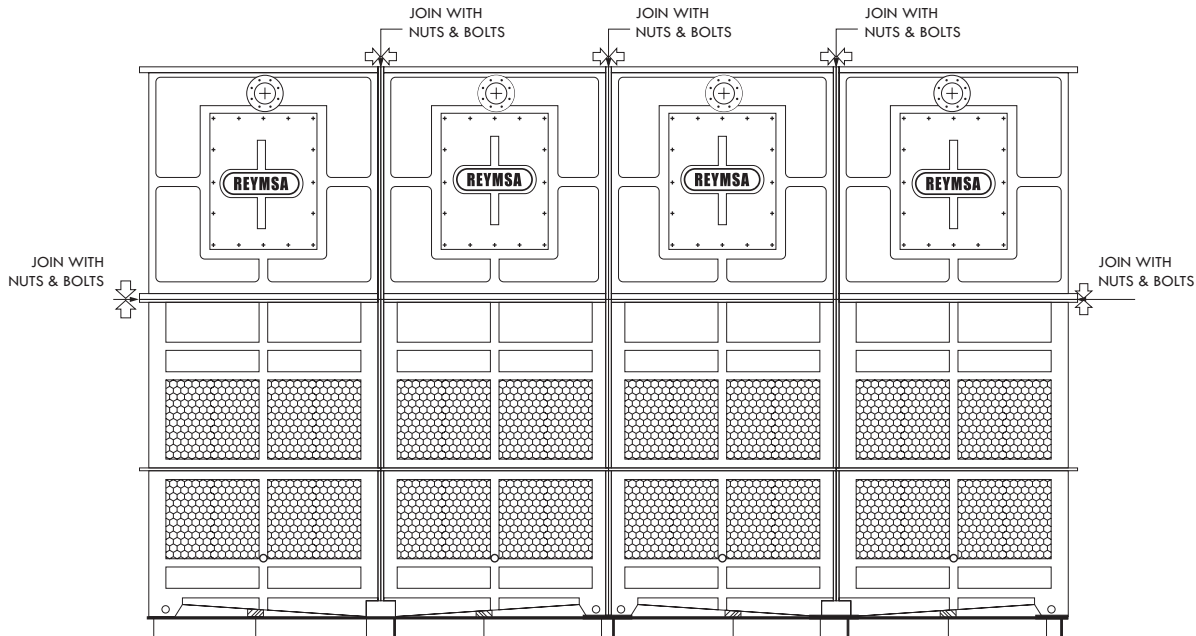

Figure A-29: Tower body section installation

L. Place tower Cover Section 1 on top of tower Body Section 1, making sure that the bolt holes on Tower Cover Section 1 are aligned with the perforations on Tower Body Section 1. (See Figure A-30).

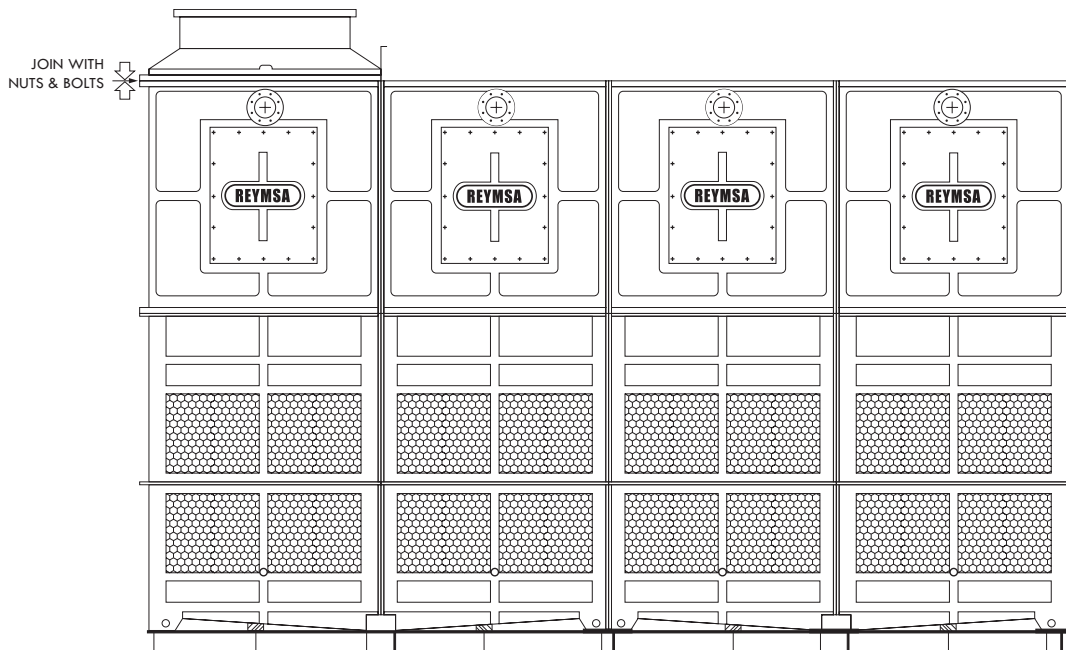

Figure A-30: Tower cover section 1 installation



M. Proceed to place remaining tower cover sections, making sure that the bolt holes are aligned. Bolt together the vertical flanges between each tower cover section using first the galvanized steel bolts and nuts (supplied by REYMSA) to join sections. Then replace the galvanized steel bolts with the stainless steel nut and bolt sets supplied by REYMSA. Proceed to bolt down and secure the horizontal flanges between each tower cover and its corresponding tower body (tower cover 1 to tower body 1, etc) with the stainless steel nut and bolt sets supplied by REYMSA, until all tower cover sections are installed (See Figure A-31).

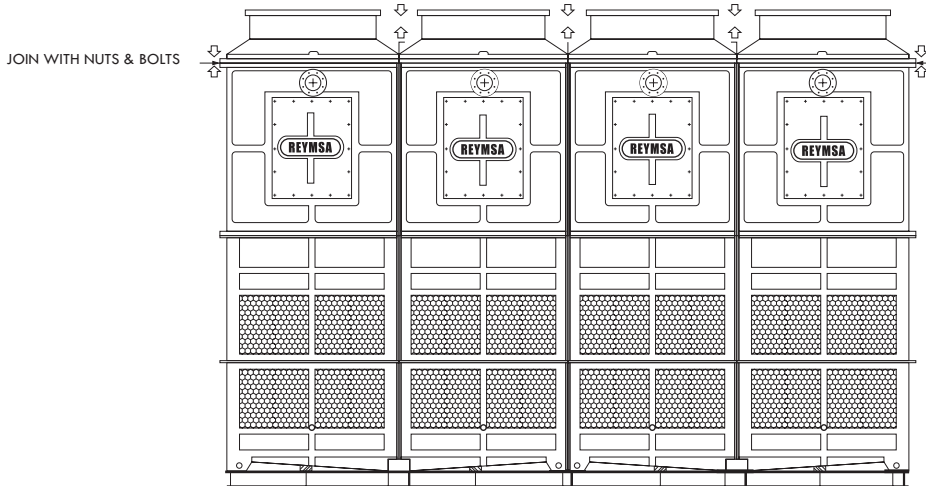

Figure A-31: Tower Cover Section Installation

N. Identify each fan duct, they are labeled with a number on the inside in the lower edge; to ensure a correct installation, this number must match the number on the corresponding receiving flange. Now place fan duct 1 on the receiving flanges of tower cover section 1 and then secure the flanges with the stainless steel nut and bolt sets supplied by REYMSA (see Figure A-32); make sure the bolt holes and the marks inside the fan duct and receiving flange are aligned (see Figure A-33).

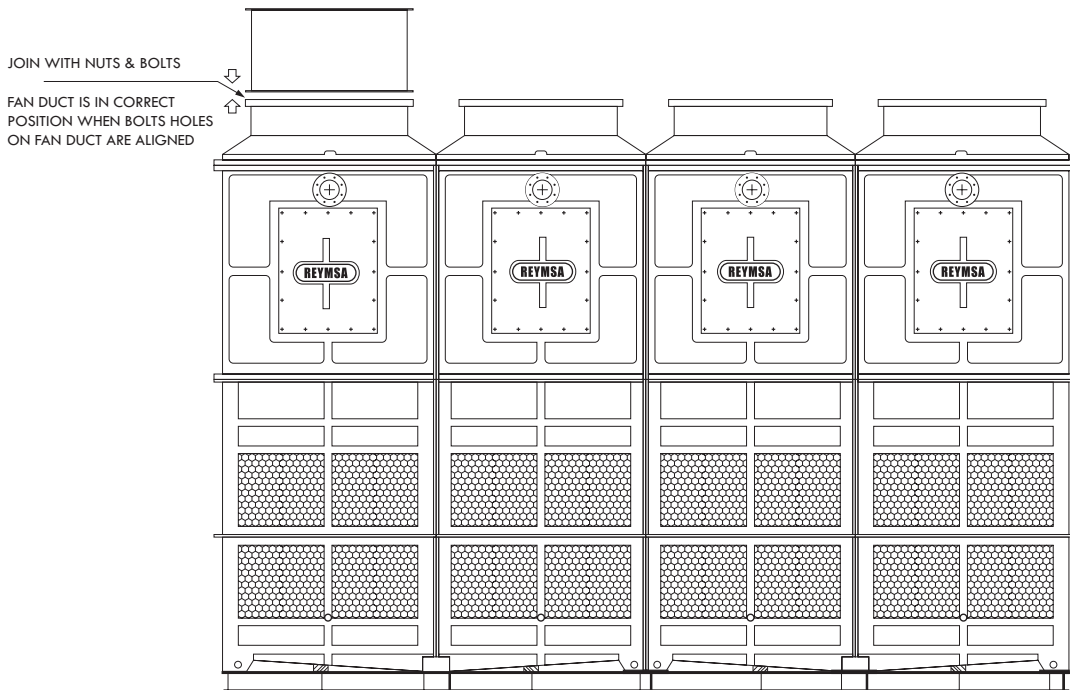

Figure A-32: fan duct 1 installation

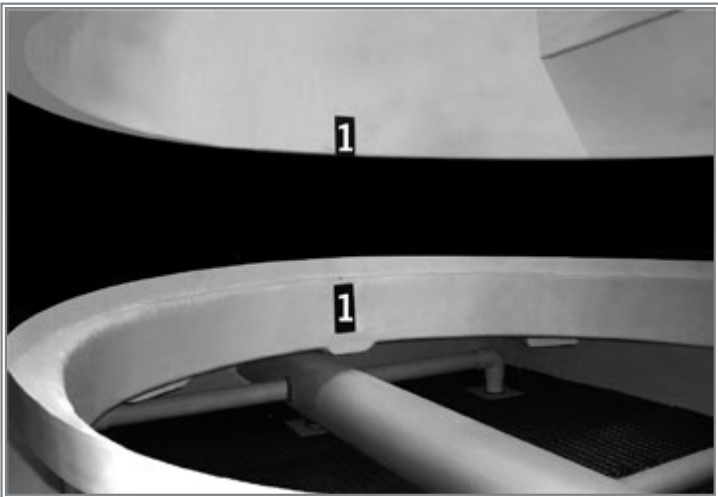

Figure A-33: Fan duct alignment

O. Place fan duct 2, following the same procedure as Step N. Repeat until all fan ducts have been installed. (See Figure A-34). Note that there are two fan ducts per Tower Cover Section.

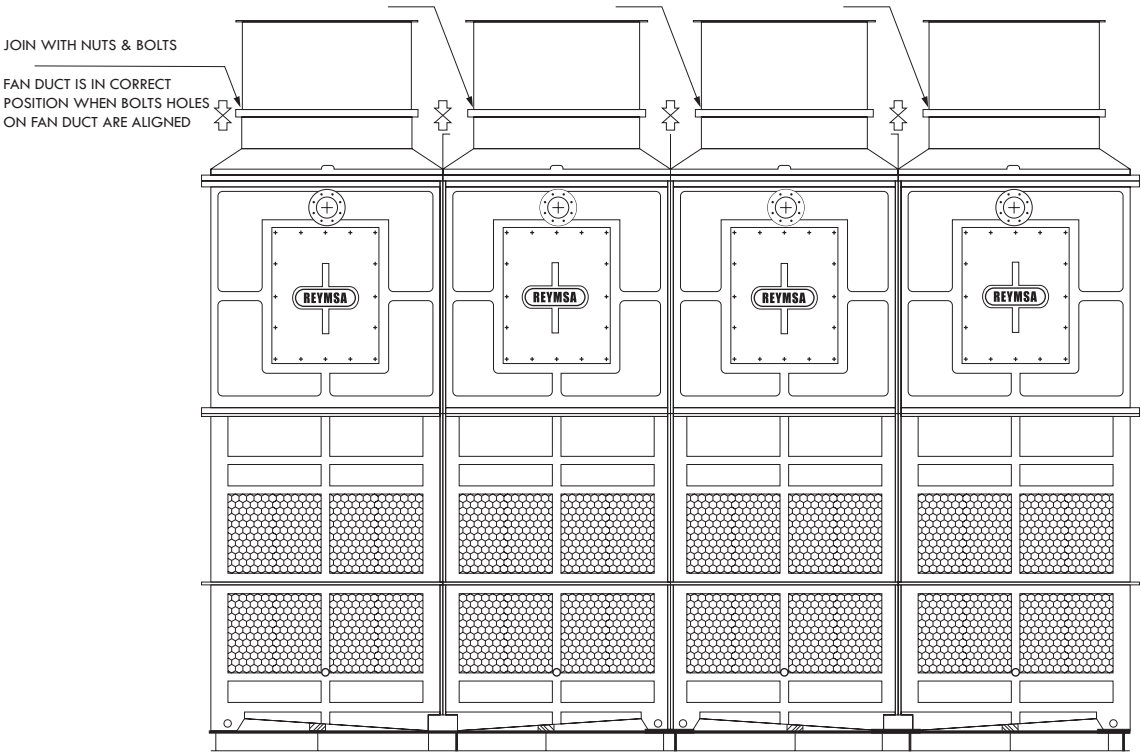

Figure A-34: Fan sections installation



A.2.5. LOW NOISE COOLING TOWERS: FAN ADAPTORS

A fan adaptor is one of the features of the LSFG-8 and SLSFG-10 Tower Series for low noise applications (see Figure A-35) that differentiate them from the HRFG Series, along with sickle fan blades and smaller fan motors.

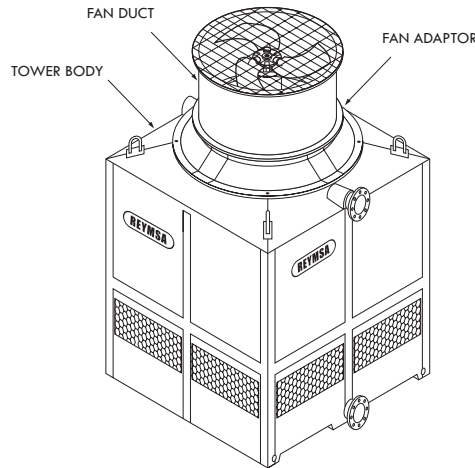

Figure A-35: Fan adaptor in single fan tower

When a fan adaptor is required, the assembly procedure for such tower would be similar to the procedures already described in Sections A.2.1, A.2.2, A.2.3 and A.2.4 (depending if it is a Single, double, quadruple fan tower or a Modular tower, respectively) with exception of the steps regarding fan duct installation. Assembly Instructions should be modified as follows:

A. Before installing the fan duct (see sections A.2.1, A.2.2, A.2.3 or A.2.4 for reference), place the fan adaptor on the receiving flange located on top of the tower (see Figure A-36); make sure the bolt holes and the marks inside the fan adaptor are aligned (Figure A-37). Then secure it using the stainless steel nut and bolt sets supplied by REYMSA.

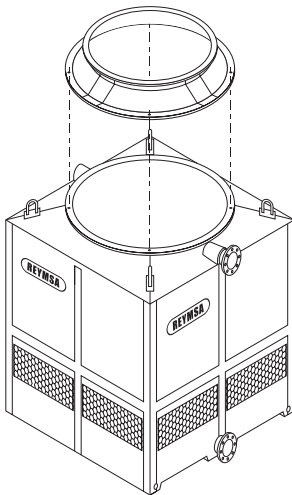

Figure A-36: Fan adaptor installation

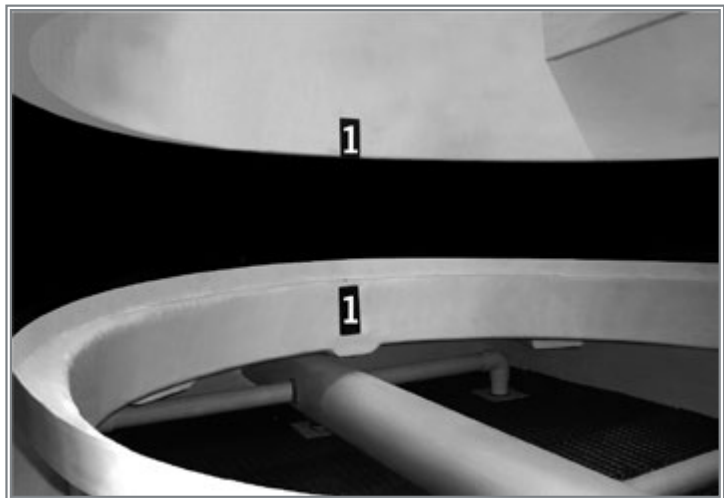

Figure A-37: Fan adaptor alignment

B. For the double fan, quadruple fan and modular towers, follow the same instructions described in previous step to install remaining fan adaptors (see Figure A-38 for an example). Each fan adaptor is labeled with a number on the inside of the upper edge; for a correct installation, this number must match the number on the corresponding receiving flange.

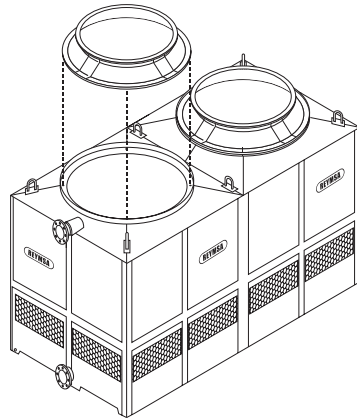

Figure A-38: Fan adaptor 2 installation

C. Then place the fan duct on top of the fan adaptor (see Figure A-39); make sure the bolt holes and the marks inside the fan duct are aligned (see Figure A-40). Then secure it using the stainless steel nut and bolt sets supplied by REYMSA.

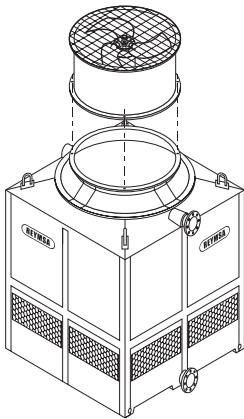

Figure A-39: Fan duct installation in a fan adaptor

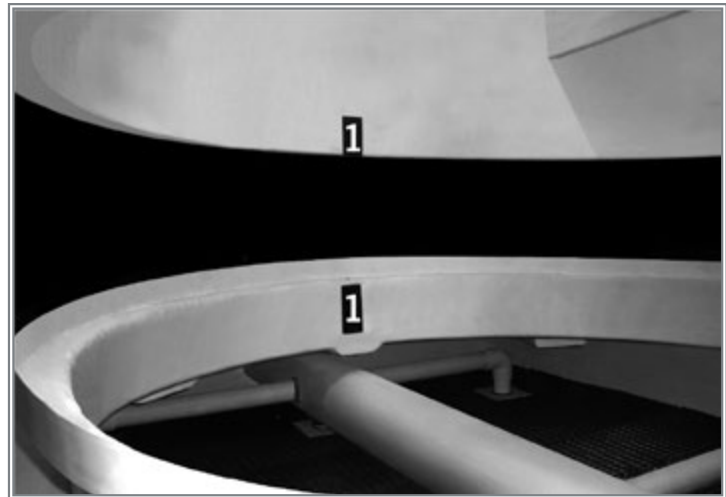

Figure A-40: Fan duct alignment

D. If there is more than one fan, follow the same instructions from previous step to install remaining fan ducts (see an example in Figure A-41). Each fan duct is labeled with a number on the inside of the lower edge; for a correct installation, this number must match the number on the corresponding fan adaptor.

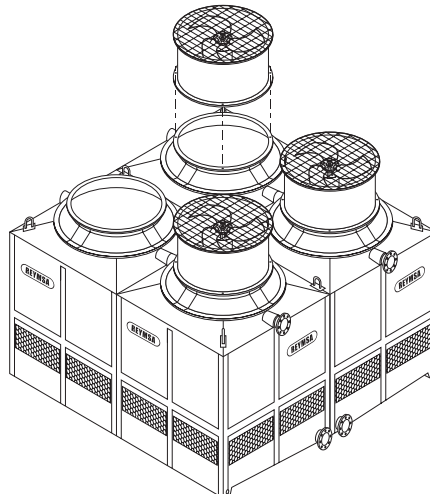

Figure A-41: Fan duct installation in a fan adaptor for a quadruple fan tower



A.2.6. MULTIPLE TOWERS

Some application will require multiple towers or basins feeding a common system. Care must be taken when multiple systems are operating together. Please observe the following recommendations:

- Install an equalizer line between towers, to maintain the same water level at the basins (see Figure A-42). Table A-2 shows the recommended sizes for the Equalizer connections.
- Install the overflow at the same level for each tower as well as manual valves at the inlet and outlet of each tower.
- An isolation valve on the equalizer line between each tower is recommended for maintenance purposes.

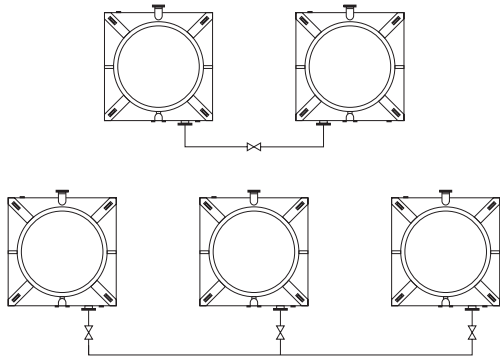

Figure A-42: Equalizer Line Installation

Table A-5: Equalizer Connection Sizes

HRFG	MODEL		FLOW RATE, GPM	Ø SIZE
	LSFG	SLSFG		
303			0 - 120	3"
404				
505			121-240	4"
606	8-606	10-606	241-360	6"
707	8-707	10-707		
708	8-708	10-708		
709	8-709	10-709		
808	8-808	10-808		
809	8-809	10-809		
810	8-810	10-810	631-1170	8"
811	8-811	10-811		
812	8-812	10-812		
714	8-714	10-714		
816	8-816	10-816		
1414	8-1414	10-1414		
1616	8-1616	10-1616	1171-1925	10"

A.2.7. BOTTOM OUTLET CONNECTION

With applications using a bottom outlet flange, follow this drawing with the instructions for connecting the outlet piping and tightening the bolts. (See Figure A-43 and A-44).

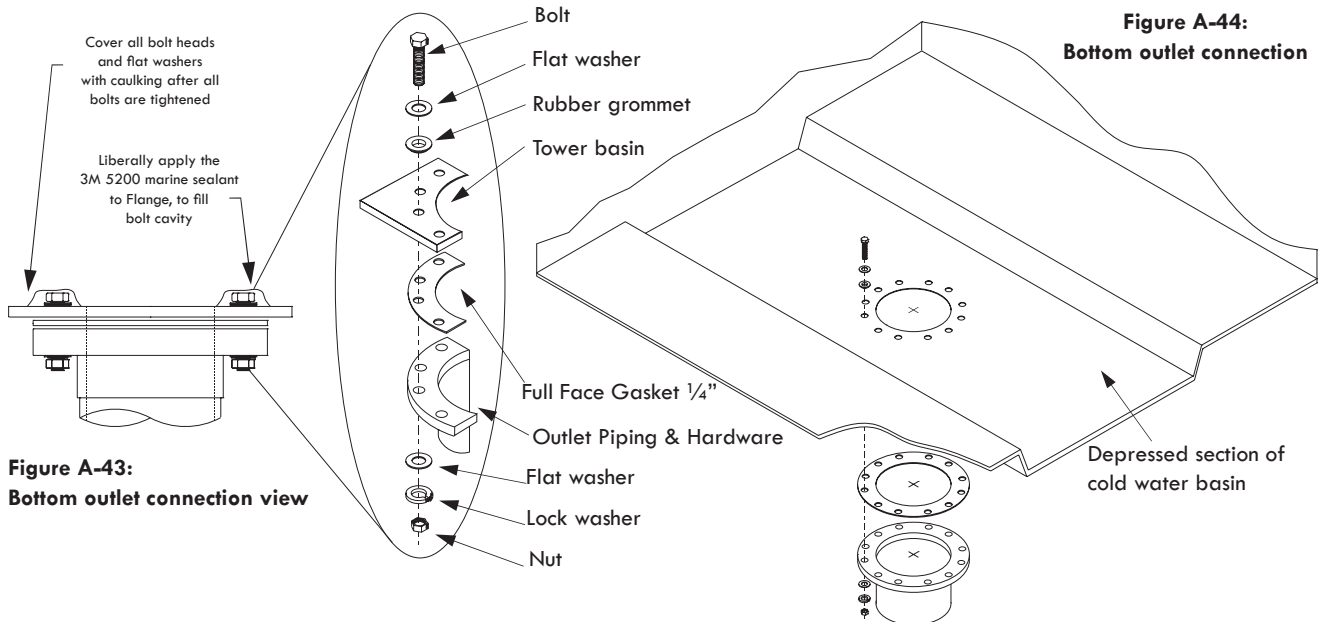

Figure A-43: Bottom outlet connection view

Figure A-44: Bottom outlet connection

Notes: All piping must be independently supported. The tower is not designed for any piping weight load; some deflection in the basin may occur. All metallic elements must be stainless steel. An isolation valve is recommended (supplied by others).

Flange Bolt Tightening Sequence

Lubricate bolt, nut threads and washer face. Assemble the flange hand tightening all the bolts, then start wrench tightening following the sequence of the numbers. During the sequence, keep any gap between flanges even all around. Tightening bolts with equal pressure, progressively increasing pressure with each complete rotation of the sequence. (As shown in figure A-45)

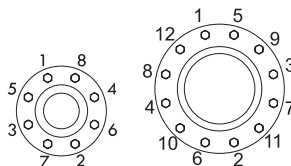

Figure A-45: Tightening sequence

NOTE: Most of the short term bolt preload loss occurs within 24 hours after initial tightening. Rechecking bolt tightness may be necessary.

A.2.8. OPTIONAL ACCESSORIES

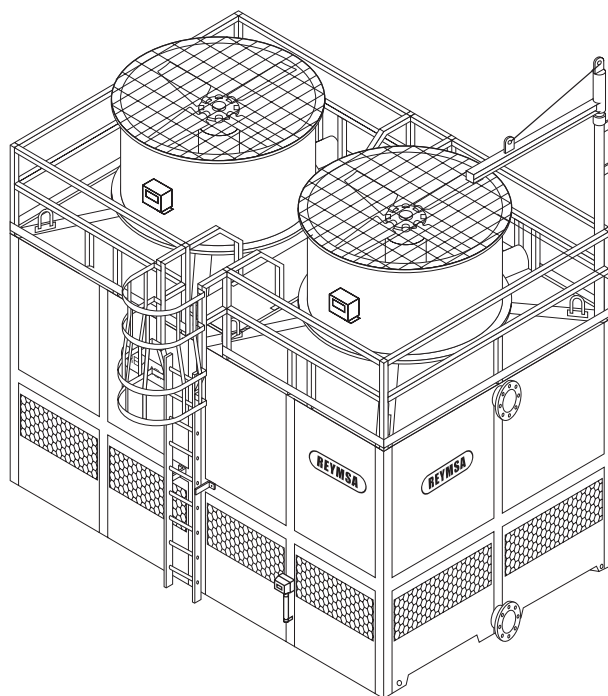

Figure A-46: Optional Accessories by REYMSA

A.2.8.1. ACCESSORIES - SAFETY

REYMSA offers a variety of optional accessories to help ensure the safety of the personnel operating the cooling tower, like ladder, catwalk, handrail, and Davit support (See Figure A-46). These accessories are designed for easy assembly with labeling on the point of contact and the part being installed.

Following is a general procedure for installation; each tower will have more specific instructions for that particular tower. Assembly Instructions and Drawings are issued for every cooling tower; refer to Appendix F, Examples of accessories assembly instructions.

1. General installation instruction:
2. The accessories are composed of several parts.
3. Each part or section has a corresponding number (on a sticker) on its inner side, for identification.
4. Every section should be jointed with stainless steel screws/bolts and washers (supplied by REYMSA).
5. Do not mix the different sections to avoid confusion or problems.

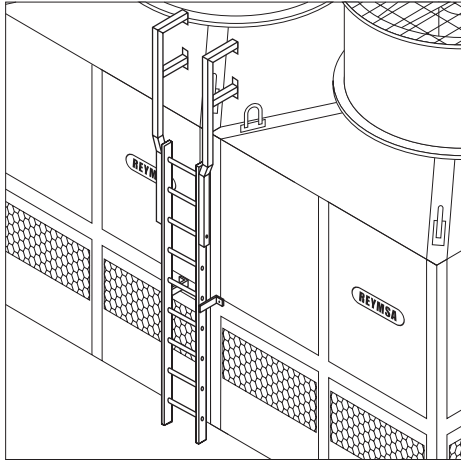

LADDER

Aluminum ladder with Stainless/Galvanized Steel supports

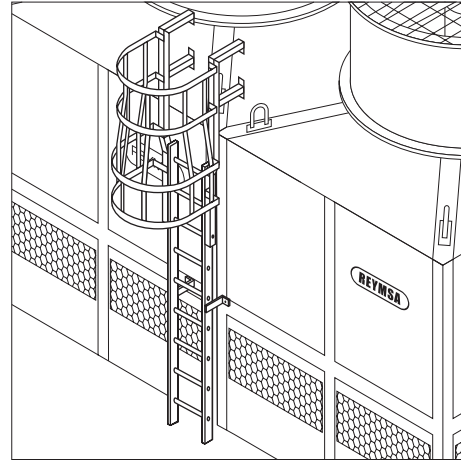

OSHA STANDARD LADDER

Aluminum ladder with Supports and OSHA Cage on Stainless/Galvanized Steel

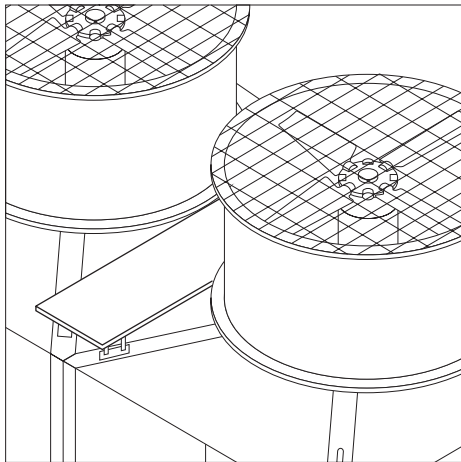

CATWALK

Non-skid Stainless/Galvanized Steel plate, supported by Stainless Steel/Galvanized structure

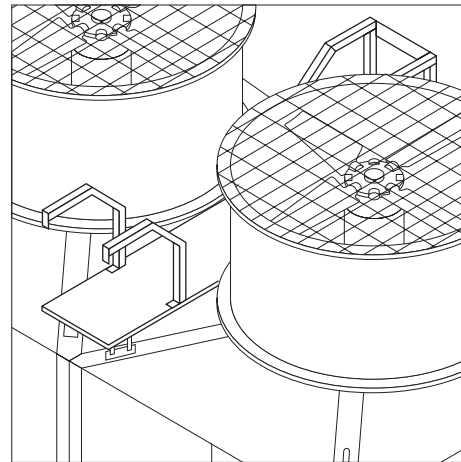

CATWALK WITH HANDRAIL

Non-skid Stainless/Galvanized Steel plate, supported by Stainless/Galvanized Steel structure, with safeguard handrails on each end

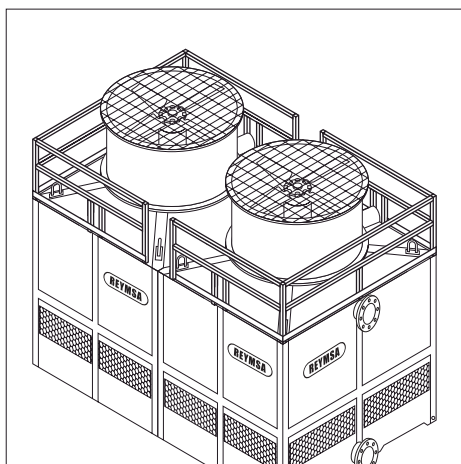

PERIMETER HANDRAIL

Stainless/Galvanized steel railing OSHA construction, including toe guard

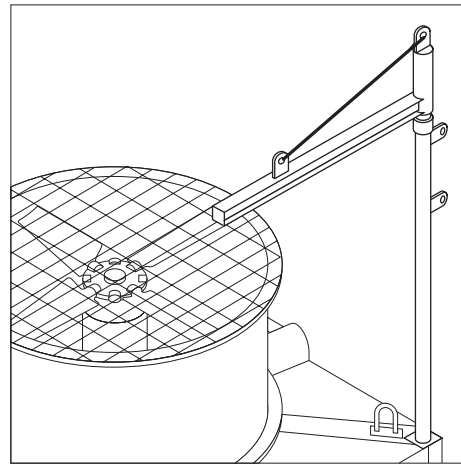

DAVIT SUPPORT

(Davit by others)
Stainless Steel tubular support for Davit

Figure A-47: Optional safety accessories

A.2.8.2. VIBRATION SWITCH

Vibration switches provided by REYMSA are shock sensitive mechanisms for shutdown of the cooling tower fan motors. These switches use a magnetic latch to ensure reliable operation whenever shutdown protection from damaging shock/vibration is desired. As the level of vibration or shock increases an inertia mass exerts force against the latch arm and forces it away from the magnetic latch causing the latch arm to operate the contacts. Sensitivity is obtained by adjusting the amount of the air gap between the magnet and the latch arm plate.



Installation instructions

Firmly secure the unit to the equipment using the base foot and mount to a satisfactory location, see Figure A-48 for an example of a recommended location.

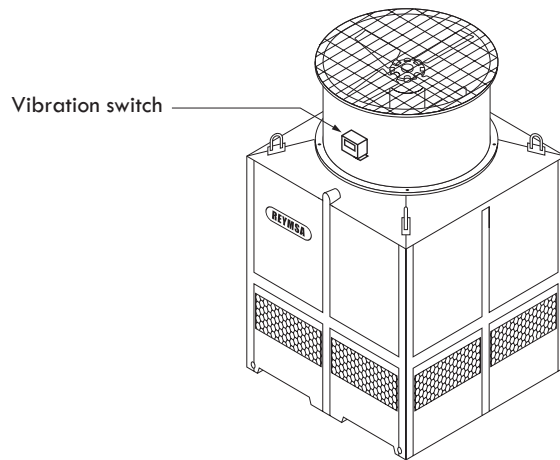

Figure A-48: Vibration Switch recommended location

Make the necessary electrical connections to the vibration switch. See Figure A-49 for electrical terminal locations and Figure A-50 for a typical electrical diagram.

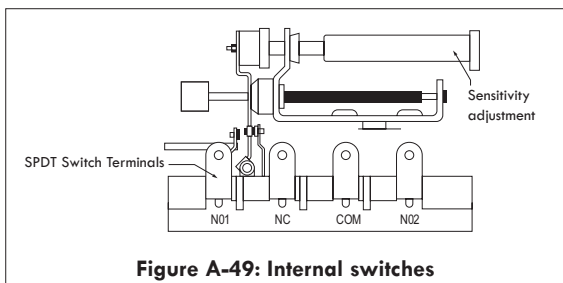

Figure A-49: Internal switches

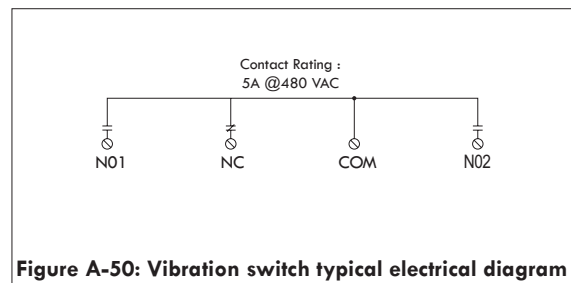

Figure A-50: Vibration switch typical electrical diagram



WARNING

Do not exceed voltage or current ratings of the contacts.

Follow appropriate electrical codes/methods when making electrical connections. Be sure that the run of electrical cable is secured to the machine and is well insulated from electrical shorting. Use of conduit is recommended.

Sensitivity Adjustment

Each vibration switch is adjusted to the specific piece of machinery on which it is installed. After the switch has been installed, the sensitivity adjustment will be increased or decreased so that the switch does not trip during start-up or under normal operating conditions. This is typically done as follows:

- Replace all covers, lids, and electrical enclosures.
- Press the reset push button to engage the magnetic latch. To be sure the magnetic latch has engaged, observe latch through the window on the Vibration switch (see Figure A-51).

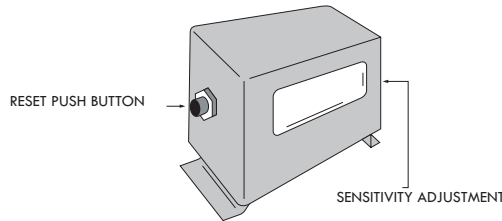

Figure A-51: Vibration switch detail

- Start the machine. If the instrument trips on start-up, allow the machine to stop. Turn the sensitivity adjustment 1/4 turn clockwise (see Figure A-52): Depress the reset button and restart the machine. Repeat this process until the unit does not trip on start-up.

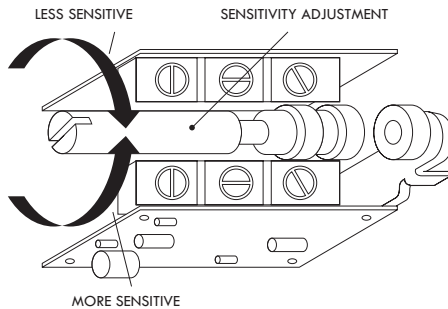

Figure A-52: Sensitivity adjustment

- If the instrument does NOT trip on startup, stop the machine. Turn the sensitivity adjustment 1/4 turn counter-clockwise. Repeat the start-up/stop process until the instrument trips on start-up. Turn the sensitivity adjustment 1/4 turn clockwise (less sensitive). Restart the motor to verify that the instrument will not trip on start-up.
- Verify that the unit will trip when abnormal shock/vibration exists.

A.2.8.3. BASIN HEATER

REYMSA offers basin heater systems designed to provide freeze protection during shutdown or standby conditions. The basin heater system consists of an electric immersion heater(s), a heater control panel and combination level sensor/thermostat well. Electric immersion heaters are sized, (kw rating, voltage, phase, and sensor cord immersion length) for the specific tower, basin size, and climate. Basin Heater Control Panel(s) are self contained and require no control wiring. The Control Panel could be self-supported or it could be mounted at the cooling tower (see Figure A-53).

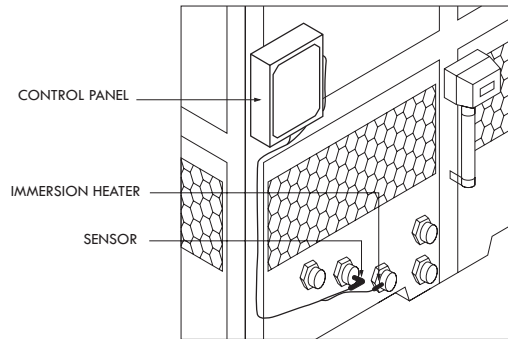

Figure A-53: Basin Heater System

Installation instructions

- Before installation, verify that power supply voltage and phasing match the heater unit.
- Two inch hubs are used to insert the heater and combination level sensor/thermostat well in the PVC couplings located at the Basin (identified by REYMSA). Immersion Heater should be located 2 inch (minimum) above the basin bottom. The access port for the combination level sensor/thermostat well should be one inch (minimum) above the heater but below the water level. See Figure A-54 for recommended distances and mounting.

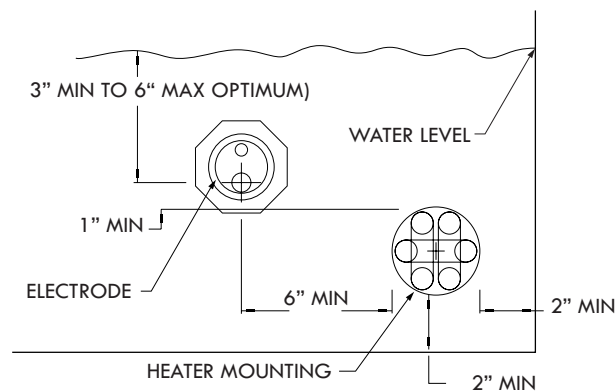

Figure A-54: Recommended basin heater mounting

- Install the immersion heater using appropriate sealing tape or compound to prevent leakage at joint.
- Sealing material must be suitable for temperature, pressure and material heated. Make sure heater is adequately supported over its immersed length.
- Install stainless steel screw plug with thermostat well and level sensor in upper coupling.
- Mount control panel so thermostat and level sensor cord will reach thermostat well and level sensor easily.



- Insert thermostat bulb in well and secure it with supplied metallic retainer.
- Plug level sensor cord onto the stainless steel sensor. Use silicone spray to disburse moisture and ease installation if required.



- Using suitable wire connect heater to panel on “T” terminals, located on right side of contactor in panel (See Figure A-55).

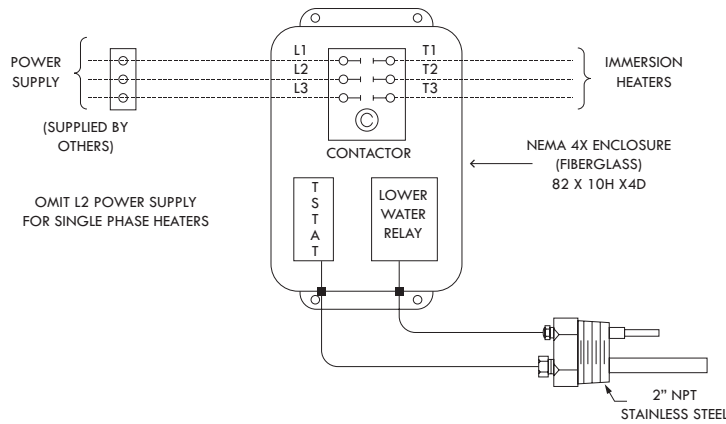

Figure A-55: Basin heater control panel diagram

- Use a suitable wire from an overload protected disconnect device, connect to the “L” terminals of the panel contactor, located on the left side of contactor in panel (see Figure A-56).
- Set thermostat in panel to meet your requirements.

A.2.8.4. ELECTRIC WATER LEVEL CONTROL SYSTEM

Electric water level control system offered by REYMSA includes water level controller, stilling chamber (standpipe) and solenoid valve for water make up (see Figure A-56 and Figure A-57).

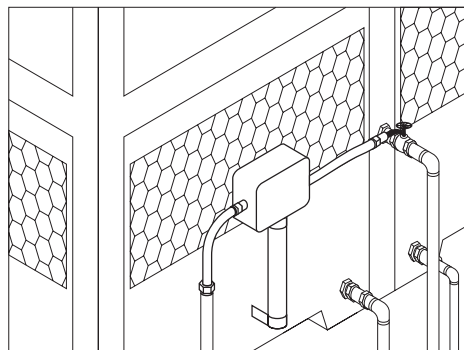

Figure A-56: Water level control system

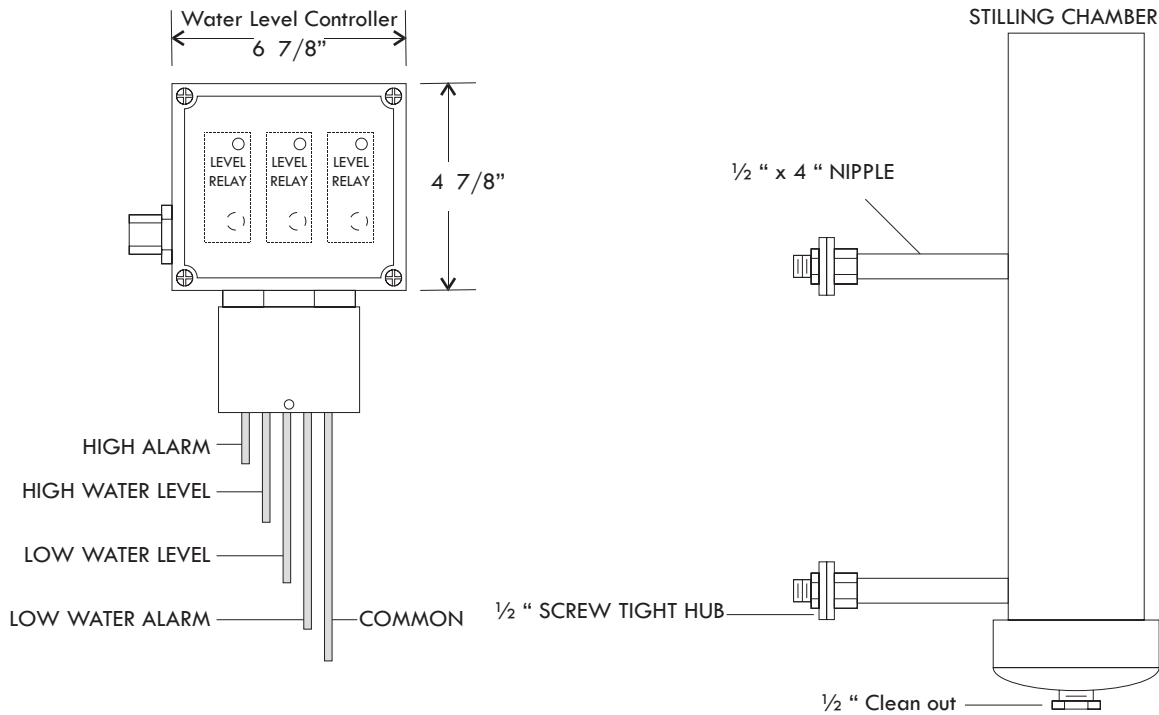

Figure A-57: Water level control parts

Installation instructions

- Clean all debris from stilling chamber before installation of level controller.
- Install water level controller in 2" stilling chamber (stand-pipe).
- The make-up water valve will activate when level falls below third longest electrode (Low water level) and will deactivate when level rises to second longest electrode (High water level).
- The Low Alarm will activate when level falls below fourth longest electrode and will deactivate when level rises to electrode height.
- The High alarm will activate when level rises to highest electrode and will deactivate when level falls below electrode.
- Electrodes should be checked and cleaned annually or more often if required.
- Set screw in collar will allow for minor level adjustments and removal of controller for inspection and cleaning.
- Electrical conduit connections must be water tight to prevent introduction of water to control enclosure.
- Relay dial must be set at #10 at all times.
- If exposed to freezing temperatures, the stilling chamber should be heat taped and insulated. Only self regulating heat tape should be used.

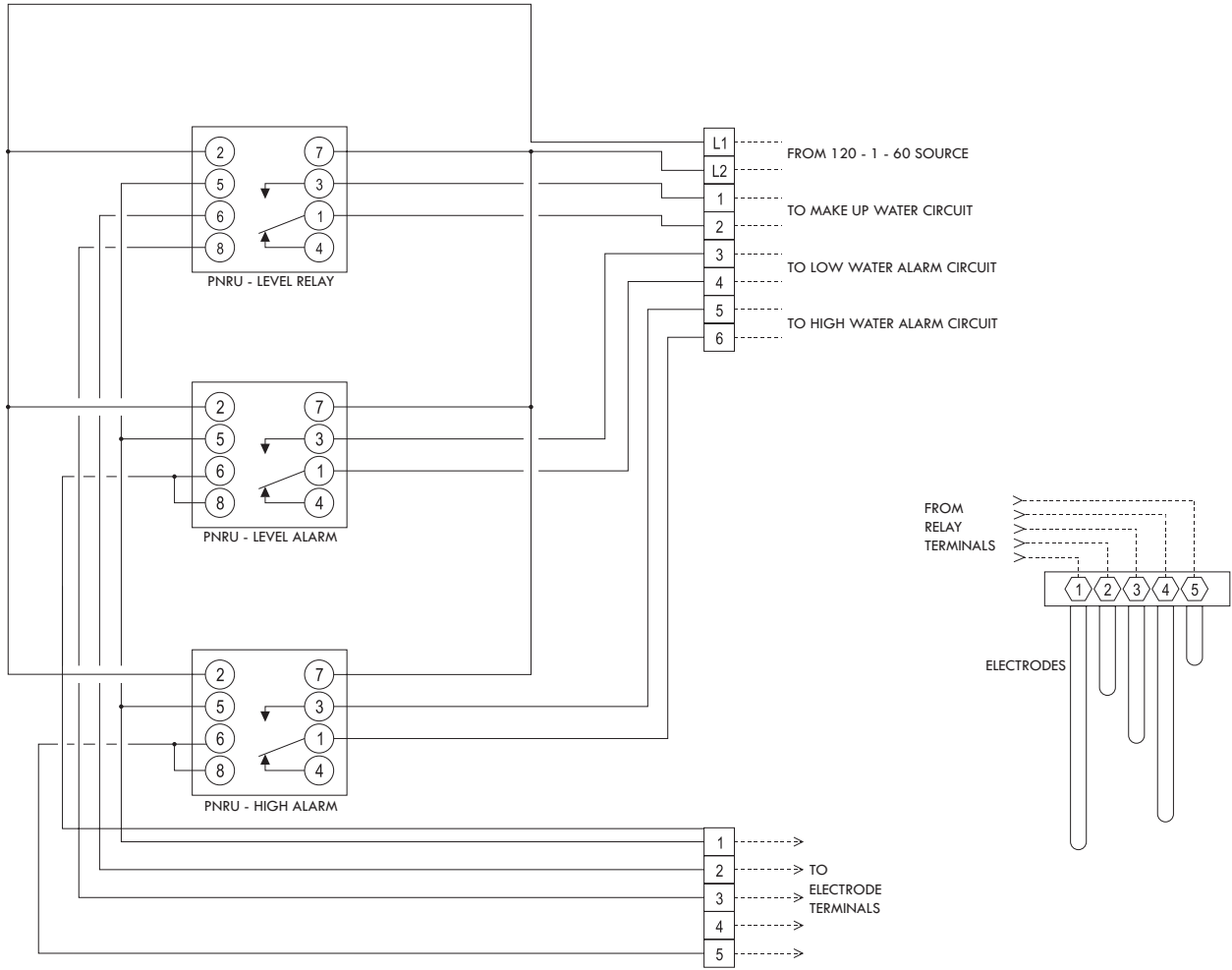

Figure A-58: Water Level and Alarm Controls Diagram

A.3. TOWER SET-UP

A.3.1. LEVELING AND TOWER SUPPORTS

REYMSA Cooling Towers should always be installed in a level surface and adequately supported. REYMSA recommends supporting cooling towers on an isolation pad and a structural base; care must be taken to ensure that the Basin Sump (the lowest portion of the tower's basin) is completely supported (see Figure A-59). Always make sure the structural base will support the tower's operational weight. Also verify that such support has the proper dimensions; always refer to factory certified drawings for construction purposes. An example of a recommended base support is shown in Appendix E; consult your REYMSA representative for more specifics.



Figure A-59: Example of structural base



CAUTION



**Tower should be installed in a level surface and adequately supported.
Failure to do so could result in cooling tower and property damage.**

A.3.2. PIPING CONNECTIONS

All connections to the cooling tower module must be field fitted after tower installation to prevent stress on the tower. All piping should be self-supported and NEVER supported by the cooling tower.



CAUTION



Piping should not be supported by the cooling tower at any time. Failure to do so could result in tower and property damage.



Piping should be adequately sized in accordance with accepted engineering principles. All piping and other external equipment must be self-supported, totally independent from the cooling tower. Also, in case your area experiences extreme cold weather, care must be taken to protect all piping located on the exterior of the building from freezing (refer to section C.4 about Cold Weather Operation).

See Figure A-60, Figure A-61 and Figure A-62, for general scheme of the different connections in the REYMSA cooling towers.

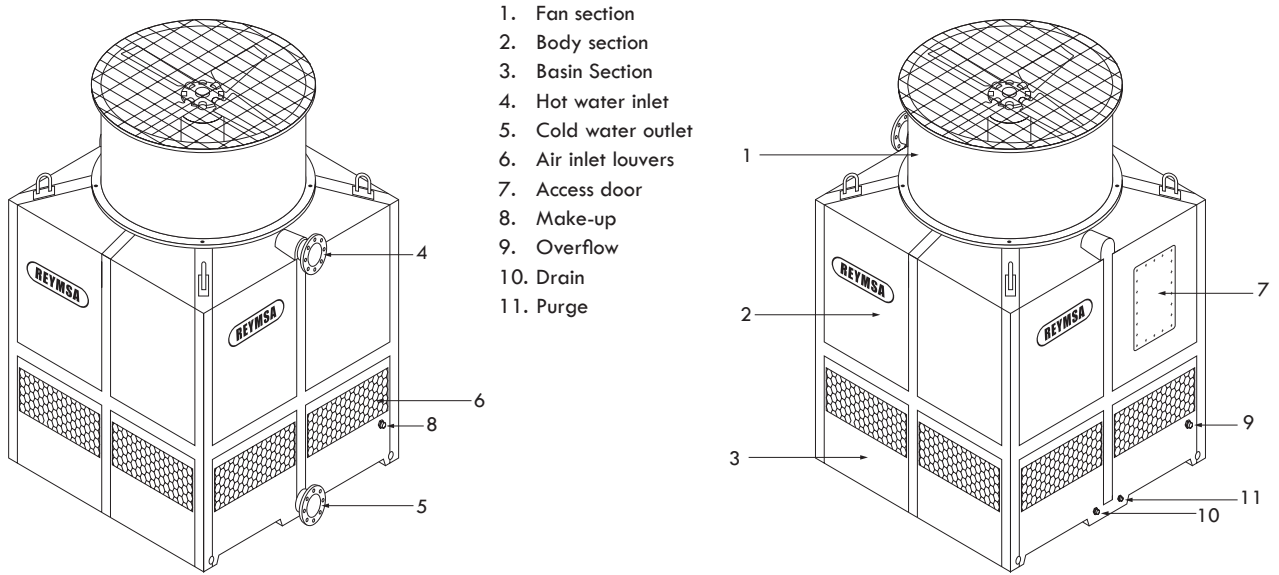

Figure A-60: Single fan cooling tower - Pipe connections

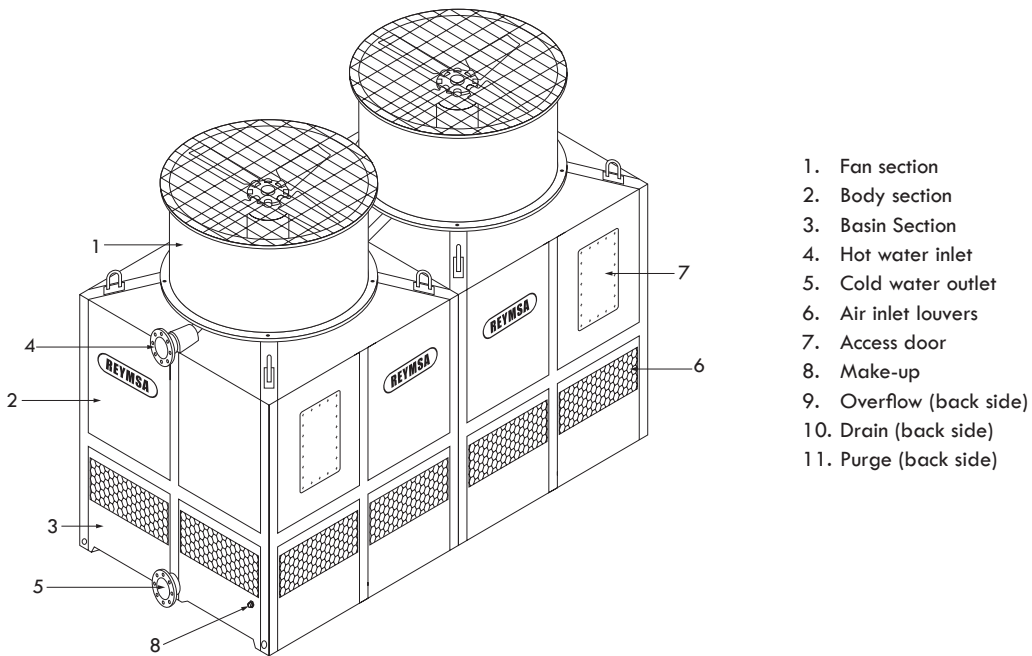

Figure A-61: Double fan cooling tower - Pipe connections

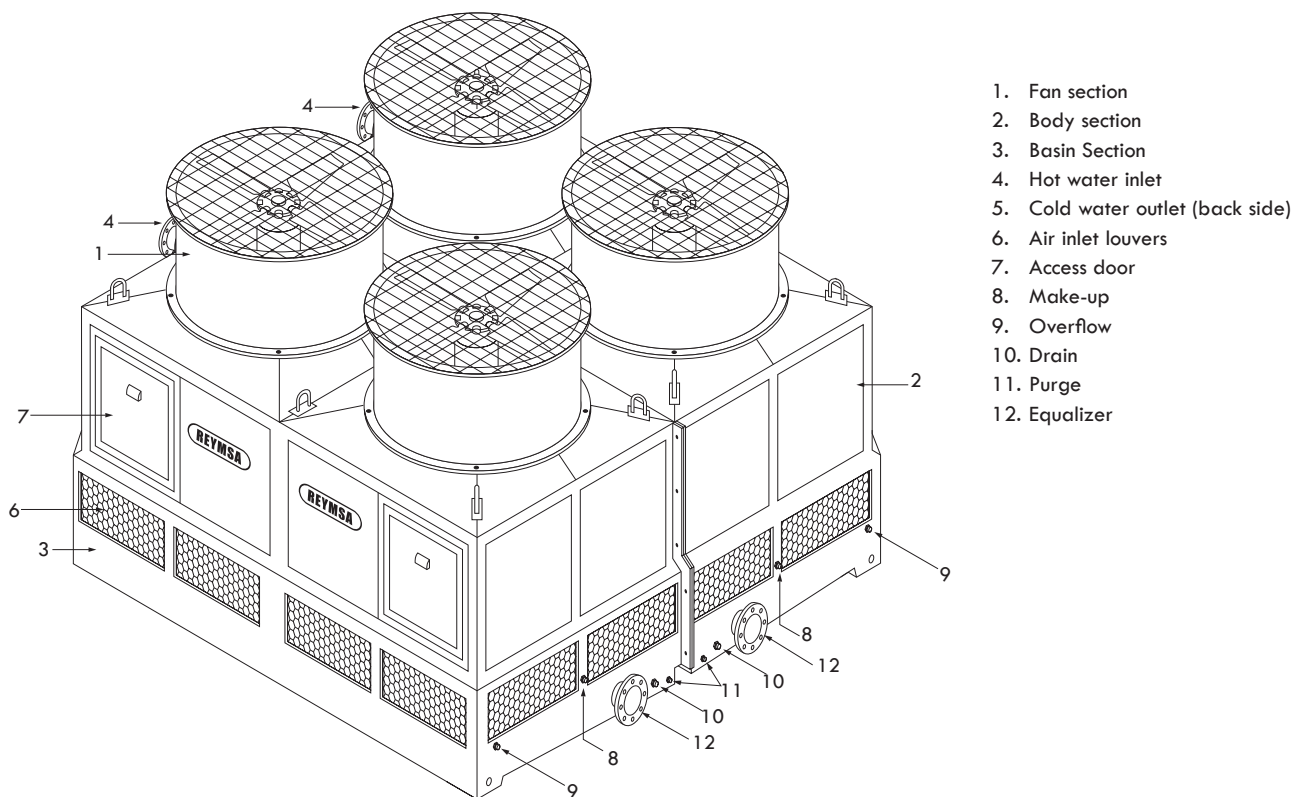

Figure A-62: Quadruple fan cooling tower - Pipe connections

▪ **Hot water inlet**

The Hot Water Inlet delivers warm water to be cooled from the process to the cooling tower distribution system. A PVC pipe flange is provided for the inlet water so that a field installed butterfly valve (supplied by others) can be installed. REYMSA recommends installing this valve in order to isolate the tower on multiple tower installations and also provides a means of adjusting and/or balancing the flow through the cooling tower. A 1/4" NPT adaptor is provided in the piping inlet between the PVC flange and the cooling tower so that a field supplied pressure gauge with a valve can be installed. This gauge is required to determine when the proper amount of water is flowing through the tower. The gauge should be selected with a 0 to 15 psig range.

▪ **Cold water outlet**

The Cold Water Outlet serves the process with the cooled water from the tower. REYMSA recommends installing a valve (supplied by others) at the Cold Water Outlet to regulate flow from the tower and also allow tower isolation.

▪ **Make-up**

Make-up water needs to compensate the water losses due to evaporation, drift and purge. To control make-up water flow, a mechanical float valve is included by REYMSA as a standard feature. A NPT connection is provided and marked as Make-up Water. Electric automatic fill valve with control is available as an optional (refer to section A.2.8.4 for electric water level control systems).

▪ **Overflow**

When excess water enters the basin, it automatically flows into the Overflow and is wasted. The Overflow connections are NPT threaded.



- **Purge**

Purging is done to remove circulating water high in dissolved solids concentration. The purge connection is NPT threaded and must have a valve (supplied by others).

- **Drain**

The drain is used to remove all the circulating water for tower maintenance and cleaning. The drain connection is NPT and must have a valve (supplied by others).

- **Equalization**

The equalization connection is used to maintain equal water levels when the system consists on more than one basin (see Figure A-63). REYMSA recommends installing a valve (supplied by others) at the Equalization line to regulate flow and allow tower isolation. Also see section A.2.5, about “Multiple towers” installation.

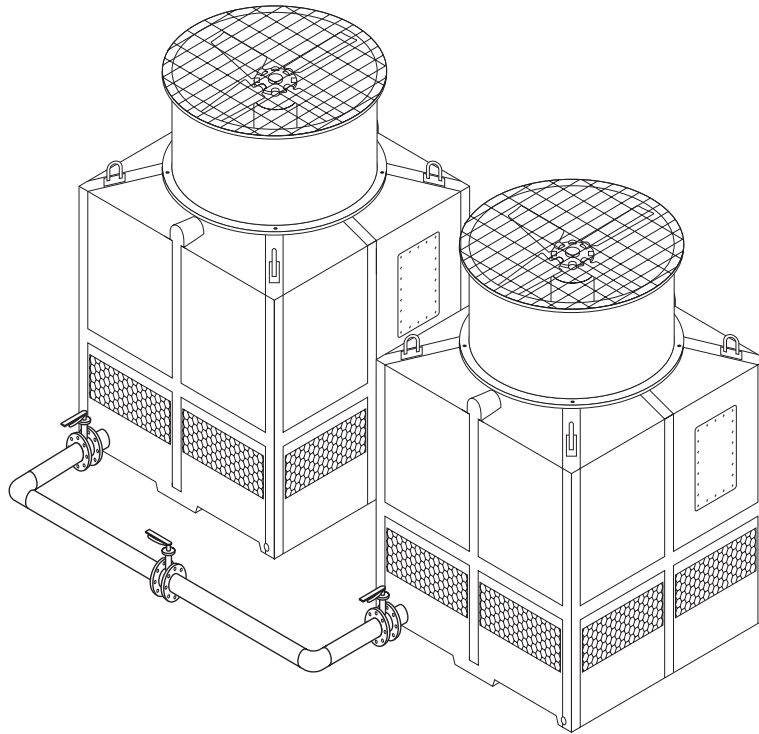

Figure A-63: Example of equalization line

A.3.3. WIRING

All electrical work should be performed by qualified personnel and in accordance to applicable electrical codes, best practices and safety standards. All wiring must conform to Federal, State and Local Codes.

CAUTION

Electrical wiring must be handled **ONLY** by qualified personnel. Failure to do so may result in severe personal injury or property damage.



CAUTION



Before proceeding, determine if there is available the proper voltage to power the motor.

Select a starter for the proper fan motor's voltage and FLA. The three-phase power starter must contain:

- A properly sized and lockable means to disconnect the main power source.
- Approved means of grounding.

A properly sized manual cut-off device suitable for outdoor use must be installed, within direct line-of-sight of the motor, on each cooling tower. As optional equipment, REYMSA recommends a vibration cut-off switch to shutdown the electrical motor in case of excessive vibrations caused by malfunctioning of the fan (see section A.2.7.2 for installation guidelines).



VOLTAGE HAZARD



This equipment is powered by a three-phase alternating current machine, as specified on the serial tag and data plate.

A properly sized conductive ground wire from the incoming power supply must be connected to the chassis ground terminal inside the electrical enclosure. Improper grounding can result in severe personal injury and erratic machine operation.

Always disconnect and lock out the incoming main power source before opening the electrical enclosure or performing non-standard operating procedures or routine maintenance.

Only qualified personnel should perform procedures that require access to the electrical enclosure while power is on.

NOTE: A ladder is necessary to access the fan motor located inside the fan duct section at the very top of the tower.



CAUTION



Use an OSHA approved ladder and follow Manufacturer's instructions for proper use. Failure to do so may result in personal injury or property damage.



CAUTION



Do not proceed without disconnecting and locking out power for the motor and pump. Failure to do so may result in personal injury or property damage.

1. Use the following procedure to wire the motor:
2. To gain access to the motor, remove the fan guard on top of the fan duct.
3. Remove the cover to the motor junction box.
4. Wire the motor following the diagram in the junction box cover. A piece of flexible conduit is installed to facilitate wiring. Ensure that the motor is properly grounded.
5. Rotate the fan by hand to verify that it freely rotates on the motor shaft. The fan should not touch the side of the tower and there should be no noises coming from the motor.
6. Place the junction box cover and fan guard.

B. START-UP

Before starting the pumps and running water through the tower, the piping system should be flushed out to remove any debris which may have gotten into the pipe during installation. Also, inspect the bottom section of the tower and remove any debris, which may have accumulated during installation. For Start-up, proceed as follows:

B.1. FILLING SYSTEM WITH WATER

- A. Open make-up valve(s) and allow basin(s) and piping to fill to the tower overflow.
- B. Check all flanged connections and piping for leaks.
- C. Bleed air from piping by opening purge valve at pump until water flows out in a steady stream without interruption.
- D. Close purge valve.
- E. Fill completely the tower's basin with water (without overflowing it).

B.2 CONTROLLING WATER LEVEL

REYMSA Cooling Towers utilize a mechanical float valve as standard (see figure B-1 or refer to Appendix H); an electric valve for automatic flow control is quoted as optional. Use the following instructions to adjust the make-up water mechanical float valve on the basin section of the tower to produce the highest water level without overflowing the tower.

- A. Remove Air Inlet Louvers within the area where float valve(s) is located.
- B. Close make-up valve(s).
- C. Check basin water level. The proper water level should be within the range of the operating level.
- D. Loosen the nut on the adjustment bolt, and then loosen the bolt itself. Do not remove the bolt.
- E. Rotate arm and stem to desired water level.
- F. Tighten adjustment bolt and nut.
- G. Restore water supply and verify that the water level is at the desired operating level.
- H. Replace Air Inlet Louvers.

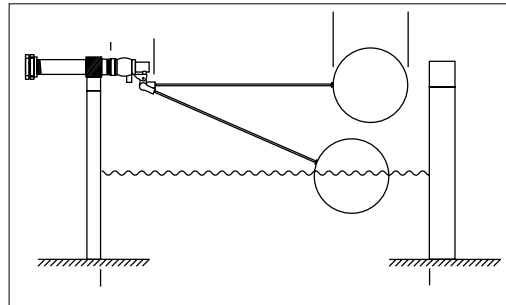

Figure B-1: Float valve installation

B.3. PUMP

CAUTION

Refer to Pump's IOM manual to ensure Pump(s) proper installation and Start-up.

- A. Before starting the pump(s), ensure that the suction piping is completely full of water.

CAUTION

Do not operate pump(s) when the suction is not full of water. Damage to the pump may occur.



B. Open inlet water valve to approximately 30% open and start one pump.



C. Allow system to operate until the float valve closes to allow the make-up water to replenish the water removed from the basin by the pump.

D. If the pump surges, shut off the pump, close the make-up valve, and adjust the float valve to a higher setting. Repeat Steps A and B.

E. Open the make-up valve to the full open position.

F. Verify the operating level in basin is within range, after the system has equalized.

G. If there are more than one pump, start remaining pumps one at a time by repeating steps D and E.

H. If the basin overflows, close the make-up valve, lower the float valve setting, and repeat Steps A to F. In case of experiencing problems with the pump(s), refer to Pump's IOM manual.

I. Shut off pump(s) if required.

B.4. FAN

A. Before starting fans for first use, ensure that the fan rotates freely, each fan should have a minimum tip clearance of no less than $\frac{1}{4}$ inch and no larger than $\frac{3}{4}$ inch. Although tip clearances are quality checked before releasing any REYMSA Cooling Tower, reinspect them to ensure there was no movement during shipping. If there is any inconformity, contact your REYMSA Representative for assistance.

B. Verify that all fan guards are in place and secure.

C. Start cooling tower fan(s) and make sure that air is entering at the bottom of the tower and discharging through the fan duct. Reverse rotation of the fan motor if required.

D. Verify that amperage of the motor does not exceed the amperage shown on the data plate. If this happens the pitch of the fan blades must be adjusted to decrease the amperage, but not less than 10% of the value described on the data plate. To adjust the pitch of the fan blades, call your local REYMSA representative for assistance.

E. The sound data included in engineering data sheet is only a theoretical calculation, and should be used only as guideline.

Never:

- Operate the fan when the access door is removed.
- Remove access door while fan is in operation.
- Operate the fan when the fan guard is removed.



C. OPERATION

C.1. WATER DISTRIBUTION SYSTEM

Water distribution is accomplished by a non-rotating, low pressure spray nozzle system, designed to provide a uniform water distribution for a specific flow rate (see Figure C-1). Take in account the following recommendations:

- The operating flow rate of the cooling tower must be as close as possible to the design flow rate. A different flow rate, whether is lower or higher, will affect the cooling tower performance.
- The normal operation range of spray nozzles is 2-10 psi. REYMSA recommends maintaining water inlet pressure between 4-8 psig to achieve a proper water distribution. Operation below this range will cause the nozzle to produce smaller than expected spray cone, lowering fill's performance. Operation of the nozzle above this range may cause flow-induced vibration, which can contribute to nozzle blowout from the pipe adapter. Both conditions will negatively affect cooling tower performance. Never operate the nozzle continuously at pressures over 10 psig.
- If a VFD is installed, set the VFD to control the cooling tower fan to the desired process water temperature.
- Never operate temperatures above the allowed level for each material; failure to do so may result in damaged to the internal components. Refer to Table C-1 for the Maximum Continuous Operating Temperatures of the materials REYMSA uses for its fill media.



Figura C-1: Water distribution system schematic

Table C-1: Maximum Operating Temperatures for Different Fill Media Materials

FILL MEDIA MATERIAL	MAXIMUM CONTINUOUS OPERATING TEMPERATURE
PVC	140°F (60°C)
HPVC	150°F (66°C)
PP	175°F (80°C)
ALUMINIUM	> 175°F (80°C)

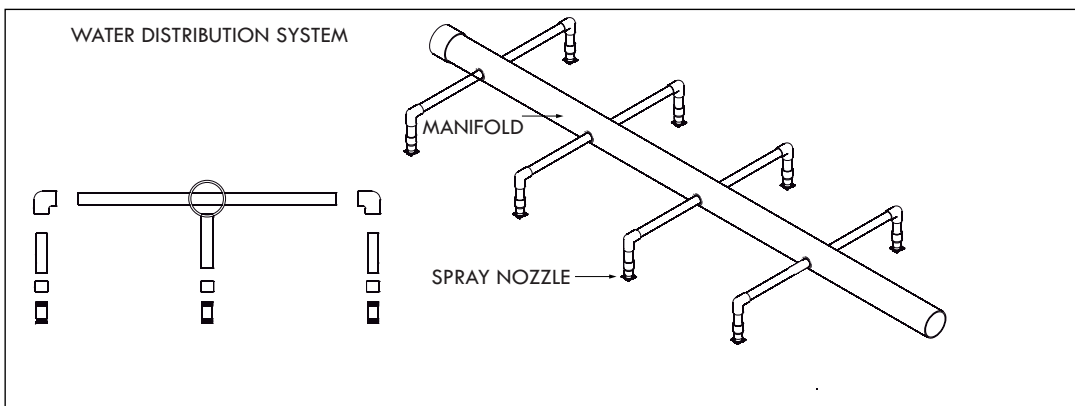

CAUTION



Operation at higher temperatures than temperatures shown on Table C-1 will damage the fill media.



C.2. WATER TREATMENT

A cooling tower is part of a carefully engineered heat exchange system. Any film or deposit which forms on the waterside heat exchange surface reduces the heat exchange efficiency of the system. System reliability can be sharply reduced by maintenance shutdowns required for removal of waterside deposits, replacement of circulation pump shaft seals damaged by suspended particles in the water, or repairs required by waterside corrosion failures. Corrosion of system components shortens the system life, as well as reducing operational reliability. However, since REYMSA Cooling Towers are constructed of FRP, corrosion is not an issue for the tower, but it is for the system.

A water conditioning program must always address the following areas to maintain system reliability:

- Suspended solids
- Scale formation
- Corrosion
- Microbiological activity control

For optimal heat transfer and tower operation, the water chemistry of the re-circulating water should be maintained within the guidelines listed in Table C-2.

Table C-2: Water Chemistry Guidelines

WATER CHEMISTRY GUIDELINES	
CHARACTERISTIC	CONCENTRATION
pH	6.5 - 9
Hardness (as CaCO ₃)	30 - 500 ppm
Alkalinity (as CaCO ₃)	500 ppm máx.
TDS (Total Dissolved Solids)	1 500 ppm máx.
Chlorides (as Cl)	450 ppm máx.
Silica (as SiO ₄)	180 ppm máx.
Sulfates (as SO ₄)	250 ppm máx.
Phosphates (as PO ₂)	15 ppm máx.

C.2.1. SUSPENDED SOLIDS

Sedimentation of solid materials occurs in the tower's basin, pipes and equipment as a product of corrosion, mill scale particles, silt or fly ash scrubbed from air by the cooling tower. It is recommended that every cooling tower is fitted with a solid separator or sand filter (see Figure C-2). REYMSA offers the sand media filter as a design option for suspended solids control.

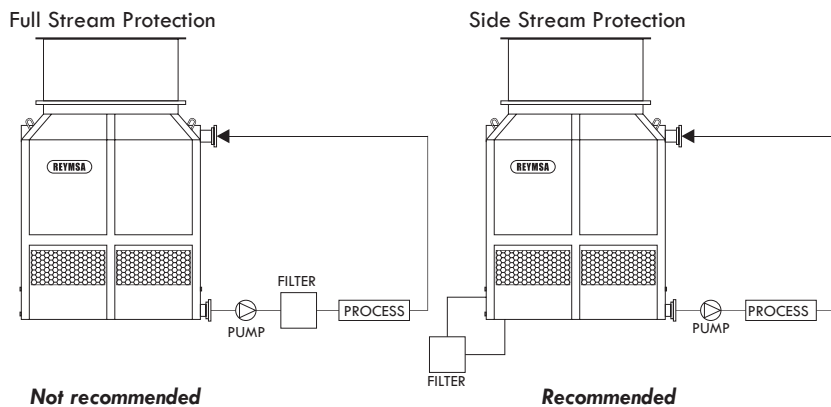

Figure C-2: Filtration system

C.2.2. SCALE FORMATION

Scale is the most widely-known water-caused trouble. Indeed the term is so familiar that it is often applied incorrectly to all solid accumulations in water systems. Scale is but a single type of fouling; others being sedimentation, corrosion, slime, etc. A true scale forms by crystallization of a dissolved salt when its concentration exceeds its solubility.

The most common formed scale consists of:

- Calcium Carbonate (lime scale)
- Calcium Sulfate
- Silica

C.2.3. BIOLOGICAL GROWTHS

Slime and algae in cooling systems are frequently spoken of and handled as though they were a single word and single problem. Algae require sunlight for their growth, which can be prevented by reducing the sunlight exposure. Minimizing the development of algae and bacterial slimes is important because they reduce the heat transfer, decrease cooling water flow, localize corrosion, and serve as a mortar for permitting rapid build-up of deposits consisting of an agglomeration of sediments, corrosion products, and scale.

The aim in cooling water treatment is microbiological control to avoid significant slime or algae growth, not the almost impossible goal of maintaining circulating water completely sterile. The many treatment chemicals available for microbiological control in cooling towers include chlorine and other compounds which yield available chlorine, some of these compounds have broad spectrum effectiveness and others are specific for a more limited range of organisms

Periodic measurement of the overall bacterial population of the water is recommended to maintain a biological control.

Finally, whenever flagrant microbiological growths develop, chemical or mechanical cleaning must be included along with micro biocide treatment in any effective program for promptly re-establishing microbiological control.

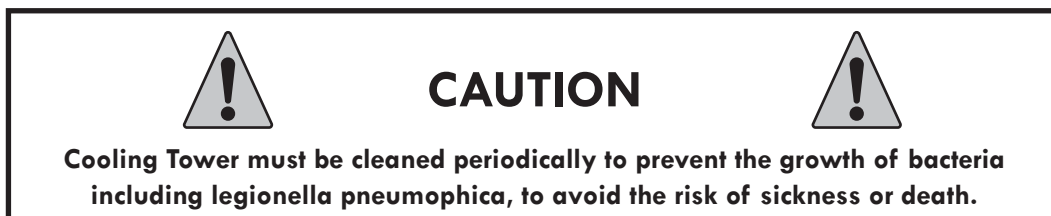

C.3. MAKE-UP WATER REQUIREMENTS

Evaporation accounts for the largest loss of water from a water cooling system and is independent of system's flow for typical operating temperatures. To achieve one ton of cooling, a tower will evaporate about 1% of process water each minute, per every 10°F range.

As this water evaporates, it leaves behind any dissolved solids it may have been carrying. If allowed to go unchecked, these solids will eventually precipitate out or scale the heat transfer surfaces. To aid in controlling dissolved solids a portion of the process water must be discharged from the system and replaced by fresh make up water thus diluting the remaining process water. Blow-down or bleed are common names given to this discharge.

Determining the amount of blow-down required is heavily influenced by the quality of water used for make up. As the dissolved solids content of the make up water increases the need for higher blow-down rates will also increase. Cycles of concentration are used in establishing the blow-down rate. The value of the cycles of concentration is the ratio between the process water concentration of dissolved solids and the make up water concentration of dissolved solids. A chemical analysis by a water treatment professional is the recommended method for determining the optimum cycles of concentration for the cooling tower water.



Water is also lost from the cooling tower itself in the form of liquid droplets, which become entrained in the cooling tower air stream and discharged with it. Known as drift, the amount of water blown out of the tower is dependent on the tower's eliminators and the flow through the tower. Generally 0.001% of the tower flow rate may be used as an estimate for drift in a counter-flow tower.

In Table C-3, there is an example which may be used for estimating water usage in a typical fully loaded system, with a 10°F temperature drop through the tower. Flows are represented as a percentage of the total flow through the cooling tower.

Table: C-3 Cycles of concentration

CYCLES OF CONCENTRATION (CC)	EVAPORATION	DRIFT	PURGE	MAKE-UP
2	1.0%	0.001%	0.999%	2.0%
3	1.0%	0.001%	0.499%	1.5%

$$\% \text{ PURGE} = \frac{\% \text{ EVAPORATION} - \% \text{ DRIFT}}{\text{CYCLES OF CONCENTRATION} - 1}$$

C.4. COLD WEATHER OPERATION

Any time a cooling tower operates in ambient temperatures 32°F or below there is a chance of the tower's water freezing. Build-up of ice can strongly affect air flow and lead to components failure. REYMSA recommends the use of an Immersion Heater System on the Tower Basin, designed to provide freeze protection. Such system consists on a heating element (3-15 kW), control panel and minimum wiring (refer to section A.2.8.3, about Basin Heater installation).

Basin Heater Operation

- Visually check that the water level is above sensor electrode. Heater should be covered with at least 2" of fluid, while heater is energized.
- The heater will energize if the temperature of the basin water falls below the thermostat set point and the water level is above the sensor level.
- A remote sump located in an indoor heated space is another option to consider. Also, electric water level control and vibration cut-off switches are useful to prevent ice formation and equipment damage and failure. Electric water level control provides an accurate control of the water level basin and eliminates the problems experienced by the mechanical float control. Ice formed on the cooling towers is one cause of excessive vibration, so the Vibration cut-off switches avoid potential damage.

If the cooling tower will operate in a freezing climate, take into account the following precautions to help lessen the chances of damaging property due to freezing water:

- Assure adequate air flow; risk of recirculation must be minimized. Recirculation can result in inlet louvers and fan freezing.
- Drain water from the tower when not in service for any extended period of time.
- On towers with a remote sump tank located inside the building, ensure that the tower and all piping on the exterior of the building drain into this tank when system is shutdown.

- All external piping that is not drained must be heat traced and insulated, as well as system accessories like water level control, make-up water valve, re-circulation pump, etc.
- Maintain the highest water temperature in the tower system that will satisfy the cooling load. Outlet water temperature must be maintained at a minimum of 40°F. The higher the water temperature, the lower the ice formation potential.
- Maintain the water flow above the design flow rate of the cooling tower. Low water flow can result in uneven water flow over the fill, which can cause ice formation.
- Reduce tower capacity by cycling fans. It is recommended the use of a Variable frequency drive (VFD) to allow the closest control of the leaving water temperature and the fan speed.
- When using a VFD, it is recommended that the minimum speed be set at 50% of full speed to minimize ice formation. Low leaving water temperature and low air velocity through the unit can cause ice formation.
- Inspect frequently the tower and the area around the tower for unacceptable amounts of ice formation. If ice formation is found, determine where the water is coming from and take corrective action.
- A simple way to manage ice build-up is cycling off the fan motors. During a period of fan's idle operation, warm water is entering and flows over the unit and helps melt the ice that has formed in the fill, basin or louver areas.

C.5 SEASONAL SHUT-DOWN

When the system needs to be shut-down for a certain period of time longer than 3 days, REYMSA Cooling Towers recommends the following procedure.

- Ensure that all electronic components (fan, motors, and control panels) are unplugged and locked out, failure to do so could result in personal injury or property damage.
- The basin and all piping needs to be carefully drained, cleaned, and blown out all liquid, making sure there's not water inside to prevent Freezing on winter season. It's recommended to use a mix of antifreeze in the last wash and vacuum it to stay clear of ice.
- As an advice, close the make up water valve and drain the line.
- To avoid any ice formation due to rain or snow and keep out dirt from inside and outside the towers components, covered them. Especially the fan discharge opening. (As shown in figure C-2)
- Taking advantage that the system is turned off, you may want to do tower service and maintenance. (Adjust motor base screw, balance and adjust fan assembly, clean the inside and outside of the equipment).
- Turn on the motor once a week for about 5 minutes. Before starting the motor, verify there is no obstruction on the fan.
- After the seasonal shut-down period you may follow the start up instruction discussed on section B.



WARNING



FAN MOTOR RECOMMENDATIONS

REYMSA strongly recommends working with a soft-starter or VFD and avoid ON-OFF thermostat as motor starter, to prevent damage on the fan and accidents. By motor manufacturer recommendation, motors lower velocity must be higher than 50% of its nominal velocity.

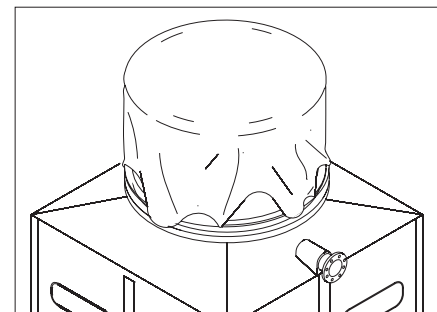

Figure C-2: Fan discharge covering



D. MAINTENANCE

REYMSA HRFG, LSFG and SLSFG Series Cooling Towers are induced-draft counter-flow cooling towers with a direct drive fan motors. This system provides a reliable operation that requires minimal routine maintenance, since there are no belts, gear boxes, shafts or bearing to lubricated or maintained.

However, proper maintenance is necessary to increase their service life. Adequate knowledge of the operation and maintenance of REYMSA cooling towers is essential for efficient and safe operation.



WARNING



Operation, Maintenance and Repair of REYMSA Cooling Towers should be done by Qualified Personnel.

REYMSA recommends that Inspection of the cooling tower should be performed yearly; appropriate cleaning or repairs should be performed if necessary; however, it is also convenient to perform regularly a general inspection for any unusual noises, vibration, water leakages, excessive drift and the set-up of initial conditions, like amps and water flow (see also section E, “Trouble-shooting”). The water quality needs to be checked also on a regular basis.

The yearly inspection routine includes the basin, the tower’s body (which includes the water distribution system, the fill media and the drift eliminators) and the fan and its motor; see on Table D-1 the Maintenance schedule recommended by REYMSA.



WARNING



Follow maintenance guidelines as recommended by REYMSA to avoid unnecessary equipment malfunction and assure good cooling tower performance.



WARNING



Do not proceed with any Inspection or Maintenance Procedure without disconnecting and locking out Power for the Motor and Pump. Failure to do so may result in personal injury or property damage.

D.1.TOWER MAINTENANCE SCHEDULE

Table D-1: Recommended tower & optional accessories maintenance schedule

		REYMSA COOLING TOWERS - MAINTENANCE SCHEDULE																							
PROCEDURE	FREQUENCY	JAN	FEB	MAR	APR	MAY	JUN	JUL	AUG	SEP	OCT	NOV	DEC	JAN	FEB	MAR	APR	MAY	JUN	JUL	AUG	SEP	OCT	NOV	DEC
Inspection for: -Unusual noises -Vibration -Water leakage -Excessive drift	Monthly																								
Check fan and inlet louvers	Monthly																								
Check water quality for biological contaminants contact your water treatment service	Quarterly																								
Basin, tower body, fan inspection and cleaning	Yearly																								
Water treatment control	Monthly																								
Clean the strainers	Monthly																								

		REYMSA COOLING TOWERS - OPTIONAL ACCESSORIES																							
PROCEDURE	FREQUENCY	JAN	FEB	MAR	APR	MAY	JUN	JUL	AUG	SEP	OCT	NOV	DEC	JAN	FEB	MAR	APR	MAY	JUN	JUL	AUG	SEP	OCT	NOV	DEC
Basin heater inspection for scale build-up and clean electrode ends and junctions box	Quarterly																								
Electric water level control inspect and cleaning all components	Quarterly																								
Vibration switch enclosure for loose wiring and moisture and adjust sensitivity	Quarterly																								
Ladders and handrail corrosion and screw loose	Yearly																								



D.2. BASIN

Basin, including the Air Inlet Louvers, should be inspected yearly and cleaned as required.

Inspection

1. Remove the air inlet louvers at the bottom of the tower to gain access to the lower section of the tower.
2. Inspect the Louvers for build-up of dirt or debris that could inhibit airflow to the tower.
3. Cover and protect the cold water outlet to prevent debris from falling into the tank or pump suction.
4. Inspect the bottom of the tower for black, wavy pieces of PVC fill. The fill is located directly above the air intakes and can be easily seen. A large amount of fill in the bottom of the tower may indicate damage, usually to the top layer. This layer can be inspected through the access doors. On new towers it is not uncommon to find some small pieces (shavings) which should simply be removed.
5. Inspect the bottom of the tower and the underside of the fill for biological growth (slime) and mineral deposits. An excessive amount of growth or deposits is an indication of inadequate water treatment. If allowed to go unchecked biological growth and mineral deposits will reduce the capacity of the tower and eventually completely plug the fill requiring it to be replaced.
6. Inspect the cold water strainers for biological growth, mineral deposits, or any dirt that may obstruct the flow of water.
7. Clean all debris from the bottom of the tower being careful not to let any fall into the cold water outlet.
8. Remove the protective covering from the cold water outlet and replace the air inlet louvers.

Cleaning(If needed):

1. Drain the water from the entire basin.
2. Clean the exterior surface with water and mild detergent.
3. Remove the air inlet louvers to gain access to the basin section of the tower.
4. Wash the Air Inlet Louvers using a low-pressure water hose. Remove any dirt or debris.
5. Cover and protect the cold water outlet to prevent debris from falling into the tank or pump suction.
6. Clean all the debris which may have accumulated at the bottom of the basin or at the strainer.
7. Flush with fresh water to remove the silt, mud or slime.
8. Inspect the sidewalls and the bottom for any possible crack or damaged part. If any damages are found, call your local Representative for assistance.
9. Remove, clean and replace the strainer.
10. Refill the basin with fresh water.
11. Remove the protective covering from the cold water outlet (mentioned above on #5).
12. Put the Louvers back into place in the cooling tower.

D.3. TOWER BODY

Tower Body should be inspected yearly and cleaned as required. This includes the Tower external casing, the Water Distribution System, the Fill Media and the Drift Eliminators.

Inspection:

1. Remove the access door to obtain complete access to the upper section. You will be able to see the top layer of the fill, the underside of the drift eliminators and the water spray nozzles, which are slightly, recessed into the black drift eliminators.
2. The spray nozzle(s) have a threaded connection and are screwed into the water distribution header. Visually inspect the nozzle(s) for any defect, obstruction or breakage.
3. Inspect the drift eliminators to ensure there is no damage or gaps between the pieces, and that they are laying flat.
4. Remove any debris found inside of the tower.
5. Inspect for biological growth (slime) and mineral deposits. An excessive amount of growth or deposits is an indication of inadequate water treatment. If allowed to go unchecked biological growth and mineral deposits will reduce the capacity of the tower and eventually completely plug the fill requiring it to be replaced.
6. Before replacing the access doors inspect the door gaskets for damage and replace if required. Clean all dirt from the face of the gasket and the surface area of the door and tower. Apply a bead of non-drying, non-shrinking caulk if there is any doubt about the integrity of the gaskets and new gaskets are not available.
7. Replace the access doors being careful not to over tighten the bolts.

Cleaning (If needed):

1. Remove the access door(s).
2. Remove the fill from the middle of the tower towards the sidewalls.
3. Clean the fill with a low-pressure water and mild detergent to remove any buildup. If fill is damaged or has excessive build up it requires replacement.
4. Remove the spray nozzle(s) from the water distribution manifold. The spray nozzle(s) have a threaded connection for easy removal.
5. Clean the spray nozzle(s) of any foreign object or trash that might be accumulated and could obstruct the proper water dispersion. Visually inspect the nozzle(s) for any defect, obstruction or breaks, in case of existence replace with a new one.
6. Unscrew the first FRP drift eliminator support and remove the drift eliminator.
7. Clean the drift eliminator with low-pressure water and mild detergent to remove any buildup. If drift eliminator is damaged or has excessive build up it will require replacement.
8. Flush the interior with low-pressure water and mild detergent to remove any buildup.
9. Inspect the sidewalls, the fill and drift eliminator supports and the water distribution manifold for any cracks or damaged part. If the drift eliminators have cracks or are damaged, call your local REYMSA Representative for assistance.
10. Reverse the procedure to install the drift eliminators, nozzle(s) and fill.
11. Before replacing the access doors inspect the door gaskets for damage and replace if required. Clean all dirt from the face of the gasket and the surface area of the door and tower. Apply a bead of non-drying, non-shrinking caulk if there is any doubt about the integrity of the gaskets and new gaskets are not available.
12. Replace the access doors being careful not to over tighten the bolts.



D.4. FAN AND MOTOR

Fan and its motor should be inspected yearly, and if required, a corrective maintenance should be performed. The motor is TEFC (Totally Enclosed Fan Cooled) with permanently lubricated ball bearings and special moisture protection on the bearings, shaft and windings.



NOTE: It will be necessary to use a ladder to access the fan and motor located in the cylindrical section at the very top of the tower.



Inspection:

1. Remove the fan guard to obtain access to the fan assemble and motor. With the guard removed turn the fan blades by hand to ensure that it moves freely and there are no indications of mechanical problems with the motor or scraping of the propeller fan against the side of the fan duct.
2. Replace the fan guard and return to ground/roof level.

Corrective maintenance:

It is recommended to do general maintenance to the fan motor every 36 months of operation, or more often if required. Maintenance should be performed only by qualified personnel.

1. Remove the fan guard on top of the cylindrical air discharge to gain access to the motor.
2. Remove the fan wheel and lower it to the ground using a lifting device.
3. Inspect the fan assemble to assure that there is no damage such as broken, loose fan blades.
4. In case of fan wheel vibration it will be necessary to have the fan dynamically balanced by a qualified technician.
5. Gently remove any build up from the fan wheel with a brush.
6. Disconnect electrical wiring and conduit to remove the motor.
7. Loosen the stainless steel bolts that connect the motor to the FRP motor support.
8. Support the weight of the motor using a lifting device.
9. Remove the connecting bolts while holding the motor steady.
10. Lower the motor to the ground.
11. Clean the outside surface of the motor to ensure proper motor cooling. Check the motor insulation at a Manufacturer's Authorized Service Station.
12. Reverse procedure to install fan and motor.
13. Replace the fan guard.

E. TROUBLE-SHOOTING

PROBLEM / SYMPTOM	PROBABLE CAUSE	CORRECTIVE ACTION
Exiting water temperature is too high	A) Excessive water flow	A) Adjust the water flow rate to design value
	B) Insufficient air flow	B) Clean fill media and drift eliminators. Verify that the amperage is not less than 10% than shown on the data plate of the motor. If so, pitch of the fan blades needs to be adjusted, call your REYMSA Representative for assistance
	C) Higher heat load through tower that designed for	C) Compare actual heat load versus design heat load. Contact your REYMSA representative for advice on possible upgrade or addition of another cooling tower
	D) Recirculation of hot discharge air back into cooling tower air inlet.	D) Eliminate obstructions that impede correct air discharge or call your REYMSA representative for advice
	E) Higher Wet-bulb Temperature than design.	E) Consult your REYMSA representative
	F) Improper operation of the water distribution system	F) Perform cleaning on the entire system (see maintenance procedure, section D.2 of this manual)
	G) Heat transfer system obstruction.	G) Inspect and make the proper cleaning and maintenance, if required (see maintenance procedure, section D.2 of this manual)
Unusual noises when the tower is operating	A) The propeller fan might be scraping against the side of the fan duct	A) Remove the fan guard to obtain access to the propeller. By hand, check to see that the propeller moves freely and that there are no indications of mechanical problems with the motor. If so, call your REYMSA representative for assistance
	B) The motor is having mechanical problems	B) Have the motor checked by qualified personnel
	C) Vibration of the fan wheel	C) Perform a dynamic balance of the fan wheel by qualified technical personnel
Pump cavitation	A) Low water operating level	A) Adjust the water make-up valve to raise the operating water level
	B) Make-up valve malfunction	B) Verify that water is available to the make-up valve. Repair or replace the make-up valve
Low cold water flow rate	A) Clogged nozzle(s)	A) Check spray nozzles and clean or replace as required
	B) Low water level on the basin	B) Check water level control and adjust if necessary
	C) The flow of water through the water outlet strainers is obstructed	C) Inspect and make the proper cleaning and maintenance, if required (see maintenance procedure, section D.2 of this manual)

PROBLEM / SYMPTOM	PROBABLE CAUSE	CORRECTIVE ACTION
The water is not falling uniformly from the fill.	A) Clogged nozzle(s)	A) Clean nozzles and replace as required
	B) Low pressure at the water inlet	B) Check pressure at the inlet and adjust as necessary (while pumps are running).
	C) Obstructed fill media	C) Inspect and perform cleaning and maintenance if required (see section D.2 of this manual)
Water leaking around the access door	Improperly installed or damaged gasket	Ensure that the bolts attaching the access door are all in place and are properly tightened. If leakage does not stop it will be necessary to take the tower out of service to inspect or replace the gasket
Water leaking from a crack in the fiberglass	The tower was not handled properly during installation or some other impact has occurred	Call your local REYMSA Representative for advice
Water leaking through the air inlet louvers	A) High water operating level	A) Adjust the water make-up valve to a lower operating level
	B) System water is overflowing the tower when pumps are stopped	B) Check piping height, grade and check valve in pump discharge
	C) Excessive water flow through the tower	C) The tower should have been installed with a water pressure gauge and throttling valve at the water inlet. Check the pressure reading at the tower inlet and ensure that it does not exceed the recommended pressure for each tower. Use the throttling valve to adjust the pressure. Cooling towers are designed to operate between 2 psig and 10 psig at the tower inlet, REYMSA recommends to work between 4-8 psig
	D) Damaged louvers	D) Replace the louvers
Excessive Drift	A) Excessive water flow through the tower	A) The tower should have been installed with a water pressure gauge and a throttling valve at the tower inlet. Check the pressure reading at the inlet and ensure that it does not exceed recommendations. Use the throttling valve to adjust the pressure
	B) Drift Eliminators are damaged, are not lying flat or there are gaps between them	B) Inspect the drift eliminators to ensure that there is no damage, that they are lying flat and that there are no gaps between them
Excessive accumulation of debris or dirt in the bottom of the basin	Unsatisfactory water treatment	Remove the debris and dirt while the tower is out of service

APPENDIX A: PHOTOGRAPHIC SEQUENCE - SINGLE FAN TOWER INSTALLATION

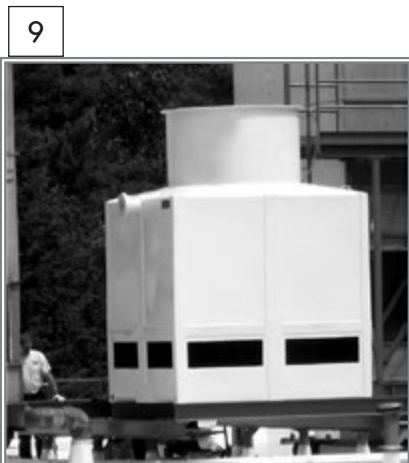
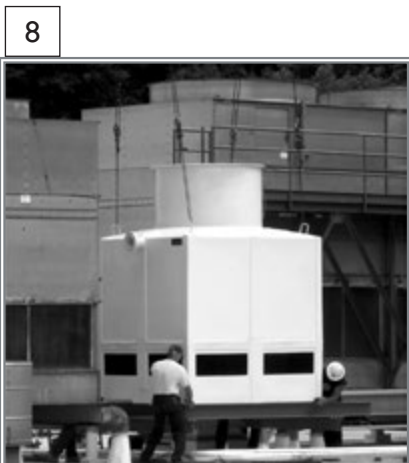
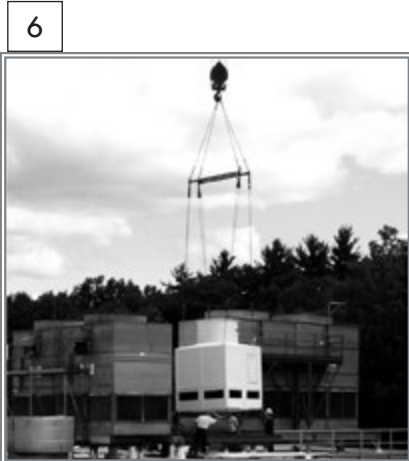
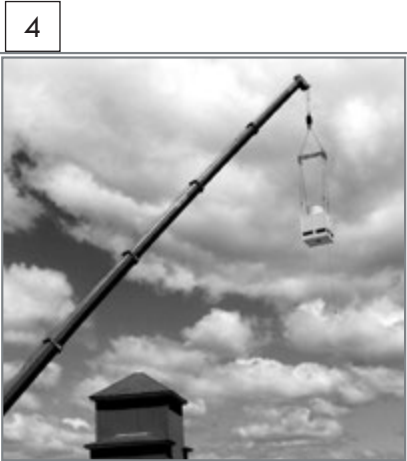
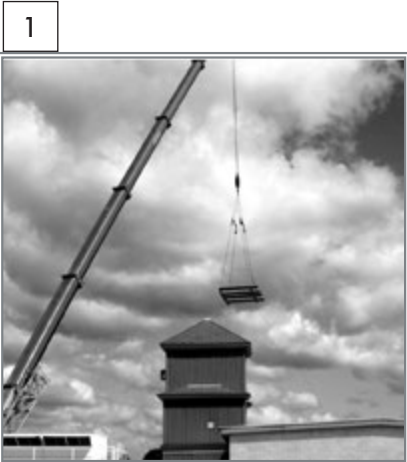



APPENDIX B: PHOTOGRAPHIC SEQUENCE - DOUBLE FAN TOWER INSTALLATION

1



2



3



4



5



6



APPENDIX C: PHOTOGRAPHIC SEQUENCE - QUADRUPLE FAN TOWER INSTALLATION

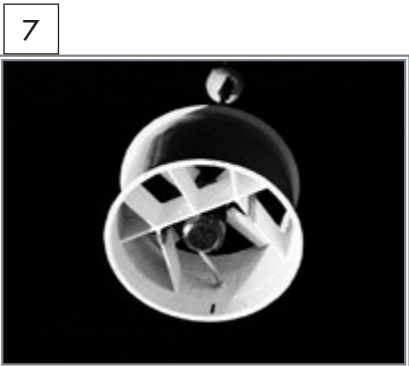
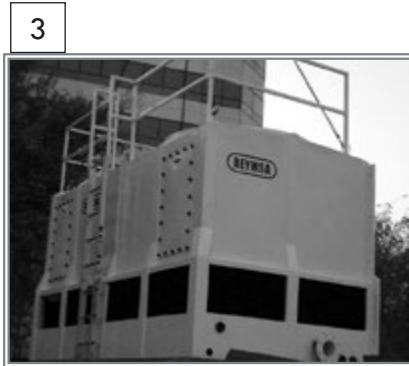



APPENDIX D: PHOTOGRAPHIC SEQUENCE - MODULAR TOWER INSTALLATION



APPENDIX D: PHOTOGRAPHIC SEQUENCE - MODULAR TOWER INSTALLATION

13



14



15



16



17



18



19



20



21





APPENDIX E: EXAMPLE OF STRUCTURAL BASE FOR A REYMSA COOLING TOWER.
FOR REFERENCE ONLY

RECOMMENDED SUPPORT FOR REYMSA COOLING TOWER MODEL HRFG-4041XX

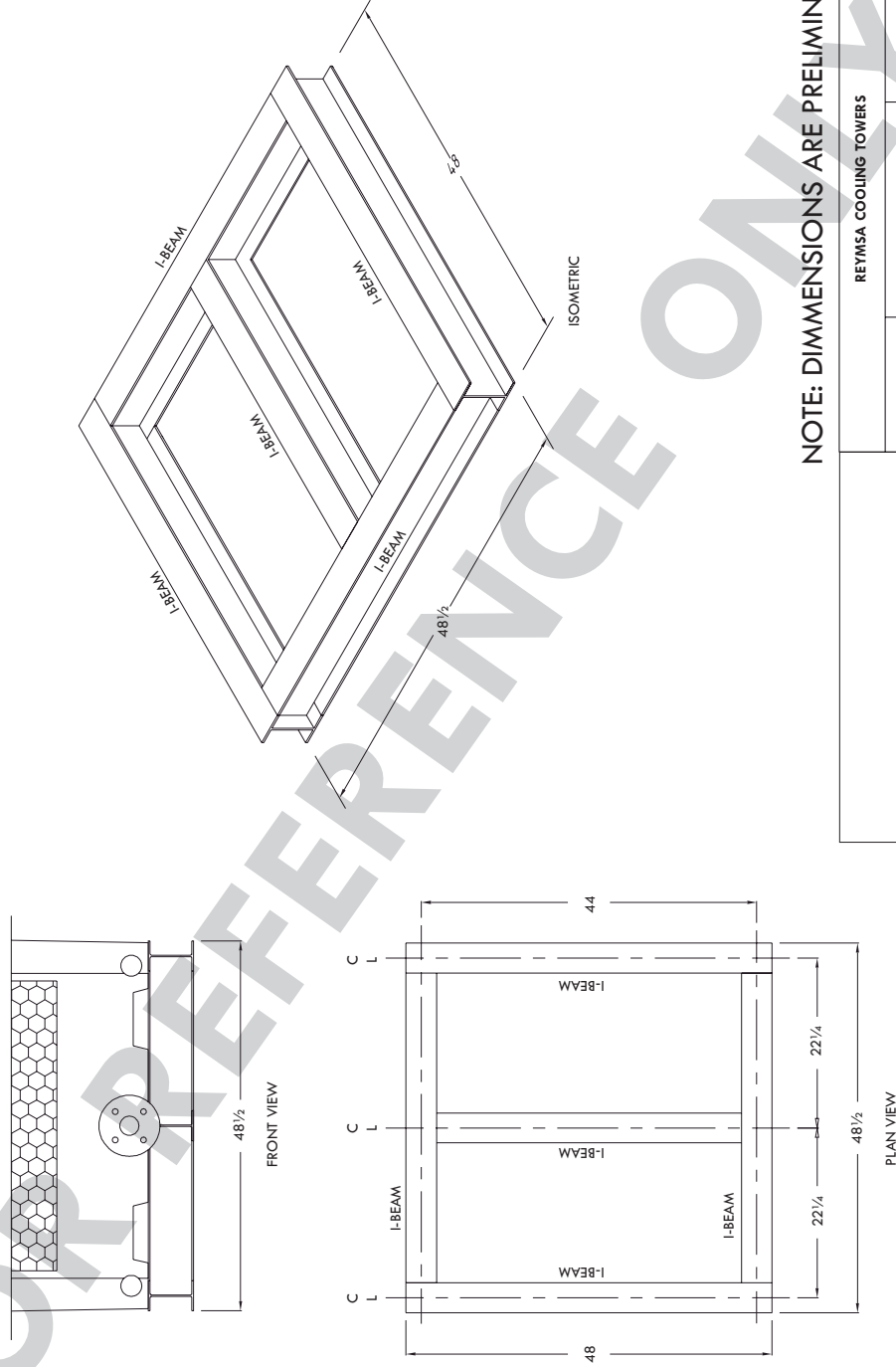

NOTE: DIMENSIONS ARE PRELIMINARY



REYMSA COOLING TOWERS			
REVISED:	MODEL:	DIMENSIONS: INCHES:	
DATE:	NAME: GENERAL ARRANGEMENT	DWG. No.	

**APPENDIX F: EXAMPLES OF ACCESSORIES ASSEMBLY INSTRUCTIONS
FOR REFERENCE ONLY**

HANDRAIL AND LADDER ASSEMBLY INSTRUCTIONS

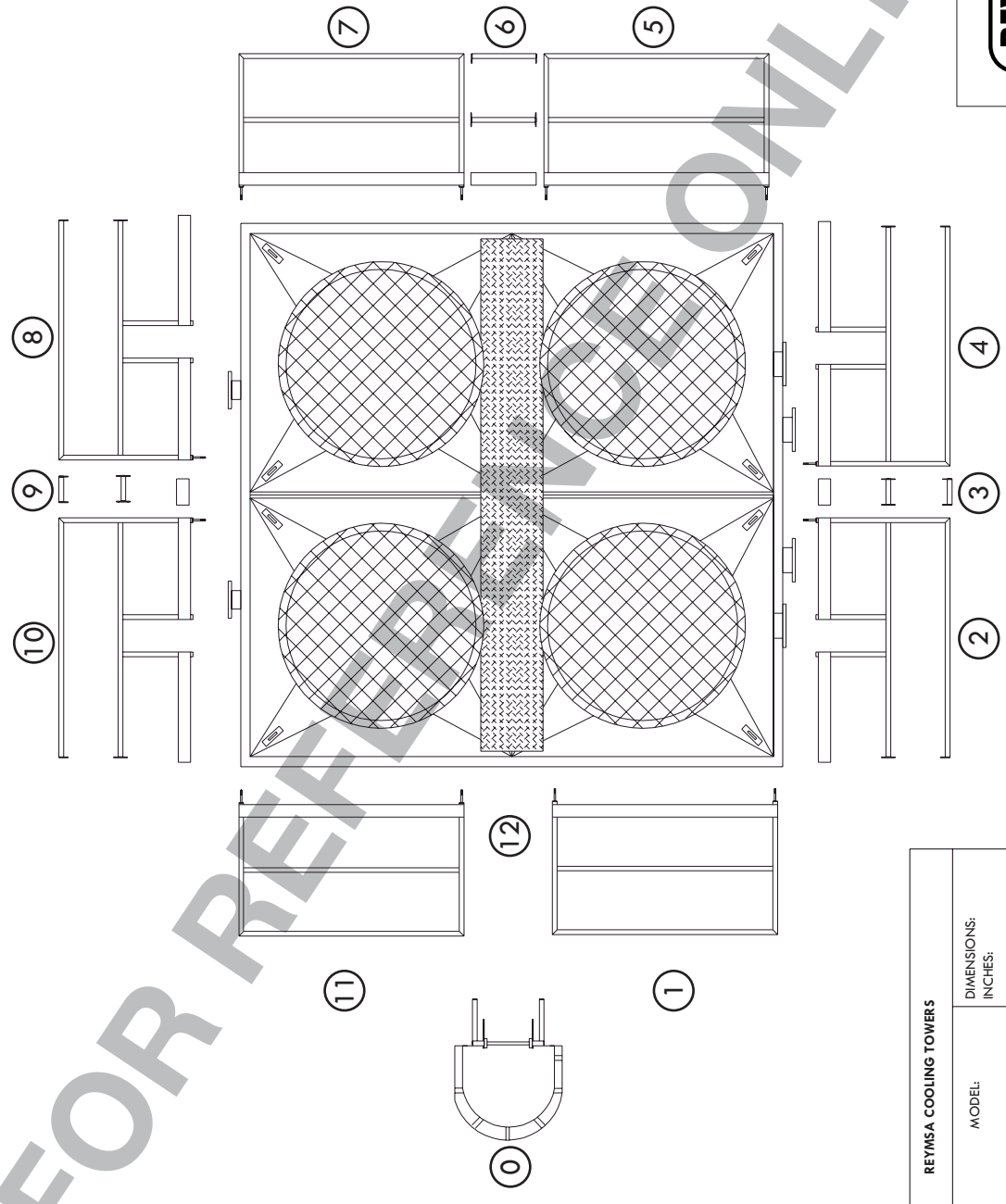

REYMSA COOLING TOWERS		
REVISED:	MODEL:	DIMENSIONS: INCHES:
DATE:	NAME: ASSEMBLY INSTRUCTIONS	DWG. No.



APPENDIX F: EXAMPLES OF ACCESSORIES ASSEMBLY INSTRUCTIONS FOR REFERENCE ONLY

HANDRAIL AND LADDER ASSEMBLY INSTRUCTIONS

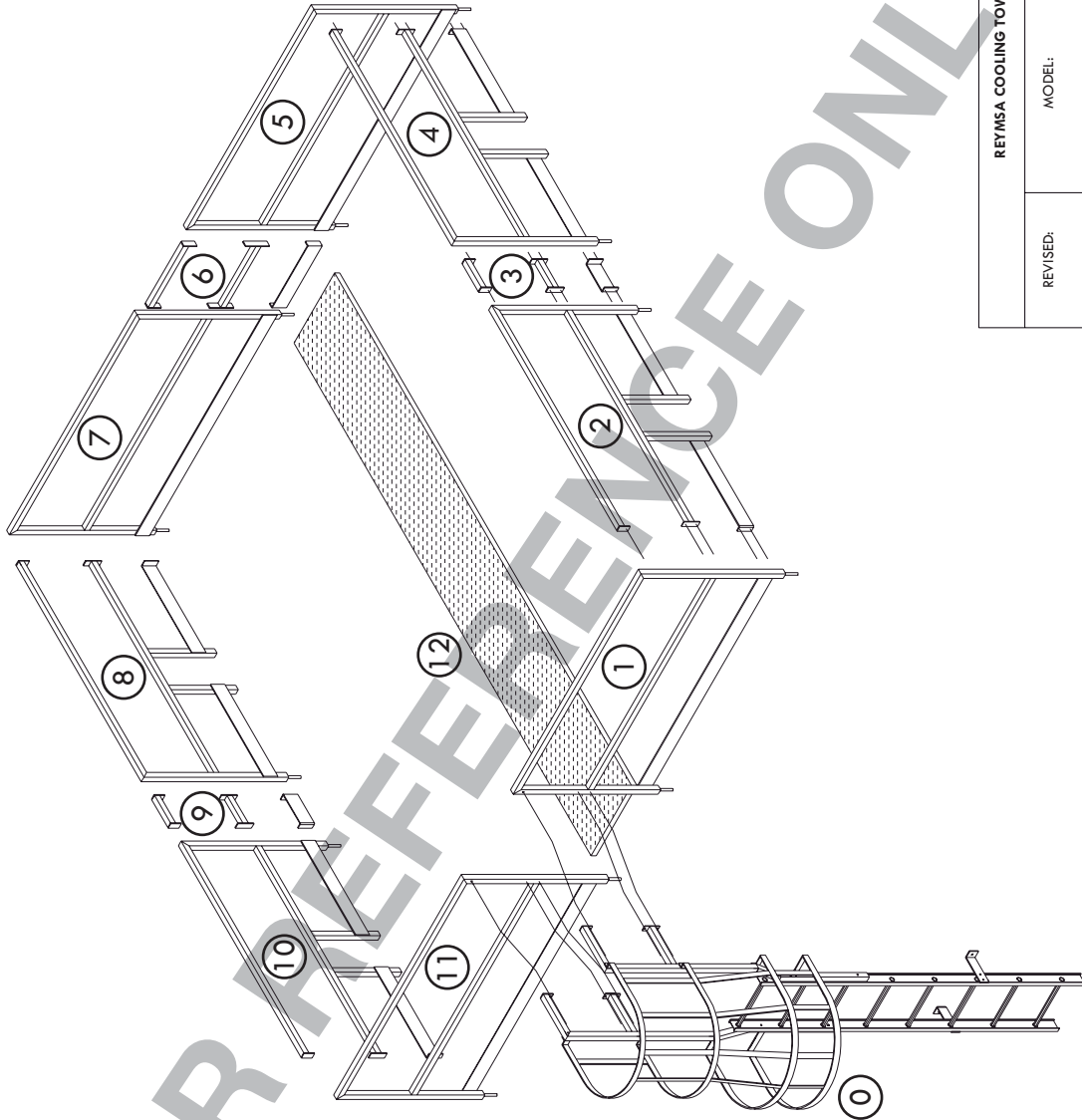

REYMSA COOLING TOWERS			
REVISED:	MODEL:	DIMENSIONS: INCHES:	
DATE:	NAME: ASSEMBLY INSTRUCTIONS	DW.G. No.	

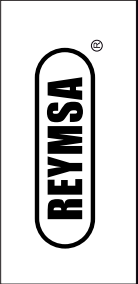

APPENDIX G: MINIMUM DISTANCES BETWEEN TOWER AND OBSTRUCTIONS

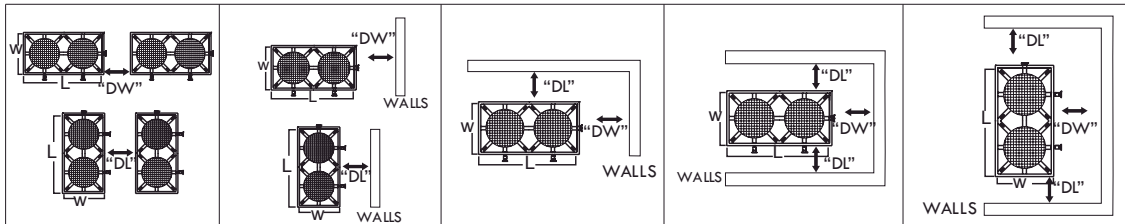

MODEL	BETWEEN TOWERS		ONE WALL		TWO WALLS		THREE WALLS (A)		THREE WALLS (B)	
	SHORT SIDE "DW"	LONG SIDE "DL"	SHORT SIDE "DW"	LONG SIDE "DL"	SHORT SIDE "DW"	LONG SIDE "DL"	SHORT SIDE "DW"	LONG SIDE "DL"	SHORT SIDE "DW"	LONG SIDE "DL"
HRFG-303	6	6	3	3	3	3	3	3	3	3
HRFG-404	6	6	3	3	3	3	3	3	3	3
HRFG-505	6	6	3	3	3	3	3	3	3	3
HRFG-606	6	6	3	3	3	3	3	3	3	3
HRFG-707	6	6	3	3	3	3	4	3	4	3
HRFG-708	6	6	3	3	3	3	4	3	4	3
HRFG-709	6	6	3	3	3	3	4	3	4	3
HRFG-808	6	6	3	3	3	3	4	3	4	3
HRFG-809	6	6	3	3	3	3	4	3	4	3
HRFG-810	6	6	3	3	3	4	5	4	5	3
HRFG-811	6	6	3	3	4	4	5	4	5	4
HRFG-812	6	6	3	3	4	4	5	4	5	4
HRFG-714	6	7	3	4	4	4	5	4	5	4
HRFG-816	6	7	3	4	4	4	5	4	5	4
HRFG-822	6	7	3	4	3	5	5	5	5	3
HRFG-827	6	8	3	4	4	5	5	5	5	4
HRFG-1414	9	9	5	5	6	5	7	5	6	6
HRFG-1616	11	10	6	5	6	6	8	6	7	6
HRFG-1622	10	12	5	6	6	7	8	7	8	6
HRFG-1627	11	12	6	6	7	7	8	7	8	7

LSFG-8-606	6	6	3	3	3	3	3	3	3	3
LSFG-8-707	6	6	3	3	3	3	3	3	3	3
LSFG-8-708	6	6	3	3	3	3	3	3	4	3
LSFG-8-709	6	6	3	3	3	3	4	3	4	3
LSFG-8-808	6	6	3	3	3	3	4	3	4	3
LSFG-8-810	6	6	3	3	3	4	5	4	5	3
LSFG-8-812	6	6	3	3	3	4	5	4	5	3
LSFG-8-714	6	6	3	3	3	4	4	4	4	3
LSFG-8-816	6	7	3	4	4	4	5	4	5	4
LSFG-8-822	6	8	3	4	4	5	5	5	6	4
LSFG-8-827	6	7	3	4	3	4	5	4	5	3
LSFG-8-1414	8	8	4	4	5	5	6	5	6	5
LSFG-8-1616	11	10	6	5	6	6	8	6	7	6
LSFG-8-1622	10	12	5	6	6	7	8	7	9	6
LSFG-8-1627	10	11	5	6	6	7	8	7	8	6

SLSFG-10-606	6	6	3	3	3	3	3	3	3	3
SLSFG-10-707	6	6	3	3	3	3	3	3	3	3
SLSFG-10-708	6	6	3	3	3	3	4	3	4	3
SLSFG-10-709	6	6	3	3	3	3	4	3	4	3
SLSFG-10-808	6	6	3	3	3	3	4	3	4	3
SLSFG-10-810	6	6	3	3	3	4	5	4	5	3
SLSFG-10-812	6	7	3	4	4	4	5	4	5	4
SLSFG-10-714	6	6	3	3	3	4	4	4	4	3
SLSFG-10-816	6	7	3	4	4	4	5	4	5	4
SLSFG-10-822	6	8	3	4	4	5	5	5	6	4
SLSFG-10-827	6	7	3	4	3	4	5	4	5	3
SLSFG-10-1414	9	8	5	4	5	5	6	5	6	5
SLSFG-10-1616	11	10	6	5	7	6	8	6	7	7
SLSFG-10-1622	10	12	5	6	6	7	8	7	9	6
SLSFG-10-1627	10	12	5	6	6	7	8	7	8	6

Suggested clearances, conditions can vary.
All clearances are expressed in feet.



APPENDIX H: WATER MAKE-UP FLOAT VALVE

REYMSA utilize as standard, a float valve device which is mechanically operated for make-up water control supply to the Towers basin.

The standard make-up assembly consist of a heavy duty bronze make-up valve connected to a plastic or cooper float ball using a threaded stem.

The cold water basin operating water level can be adjusted by repositioning the float and rod using locknuts. Is important to check that the feed water pressure is maintained between 15 and 50 psig, for proper operation of the float valve. The float valve is accessible from outside the unit through the removable air inlet louvers.



Figure AP-1: Float valve installed in a cooling tower



Figure AP-2: Copper float



Figure AP-3: Plastic float

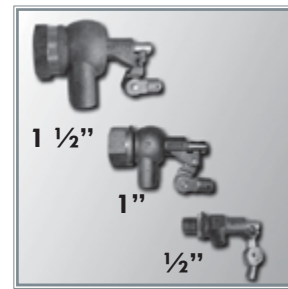

Figure AP-4: Example of valves

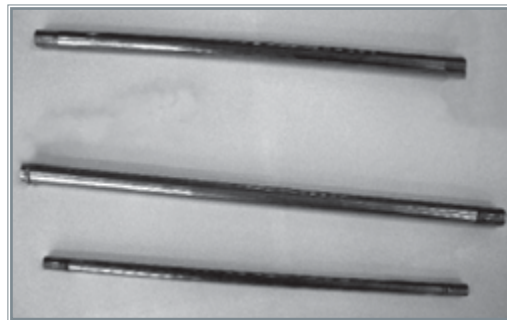

Figure AP-5: Example of stems

REYMSA COOLING TOWERS, INC.
www.reymosa.com